



US 20180166657A1

(19) **United States**

(12) **Patent Application Publication**

KIM et al.

(10) **Pub. No.: US 2018/0166657 A1**

(43) **Pub. Date: Jun. 14, 2018**

(54) **ORGANIC LIGHT EMITTING DISPLAY APPARATUS AND METHOD OF MANUFACTURING THE SAME**

H01L 27/32 (2006.01)

H01L 51/52 (2006.01)

H01L 27/12 (2006.01)

(71) Applicant: **LG Display Co., Ltd.**, Seoul (KR)

(52) **U.S. Cl.**

CPC *H01L 51/56* (2013.01); *H01L 51/0023*

(2013.01); *H01L 27/3262* (2013.01); *H01L*

27/3276 (2013.01); *H01L 27/326* (2013.01);

H01L 27/3248 (2013.01); *H01L 51/5228*

(2013.01); *H01L 51/5203* (2013.01); *H01L*

27/1248 (2013.01); *H01L 27/3258* (2013.01);

H01L 27/3246 (2013.01); *H01L 2227/323*

(2013.01); *H01L 51/5237* (2013.01); *H01L*

51/5212 (2013.01)

(72) Inventors: **SeJune KIM**, Gyeonggi-do (KR); **Joonsuk LEE**, Seoul (KR); **SoJung LEE**, Gyeonggi-do (KR); **Jin-Hee JANG**, Seoul (KR); **Jonghyeok IM**, Busan (KR); **Jaesung LEE**, Seoul (KR)

(73) Assignee: **LG Display Co., Ltd.**, Seoul (KR)

(21) Appl. No.: **15/889,659**

(57)

ABSTRACT

(22) Filed: **Feb. 6, 2018**

Related U.S. Application Data

(60) Continuation of application No. 15/434,257, filed on Feb. 16, 2017, now Pat. No. 9,923,175, which is a division of application No. 14/985,483, filed on Dec. 31, 2015, now Pat. No. 9,620,733.

Foreign Application Priority Data

May 28, 2015 (KR) 10-2015-0075397

Publication Classification

(51) **Int. Cl.**

H01L 51/56 (2006.01)

H01L 51/00 (2006.01)

Provided are an organic light-emitting display apparatus and a method of manufacturing the same. An organic light-emitting display apparatus includes: a substrate including an active area and a pad area, an anode electrode in the active area, an organic emission layer on the anode electrode, a cathode electrode on the organic emission layer, an auxiliary electrode connected to the cathode electrode, a signal pad in the pad area, and a first pad electrode connected to the signal pad, the first pad electrode covering a top of the signal pad, the first pad electrode being configured to prevent the top of the signal pad from being corroded, wherein the auxiliary electrode includes a first auxiliary electrode and a second auxiliary electrode connected to the first auxiliary electrode through a contact hole, and wherein the first pad electrode includes a same material as the first auxiliary electrode.

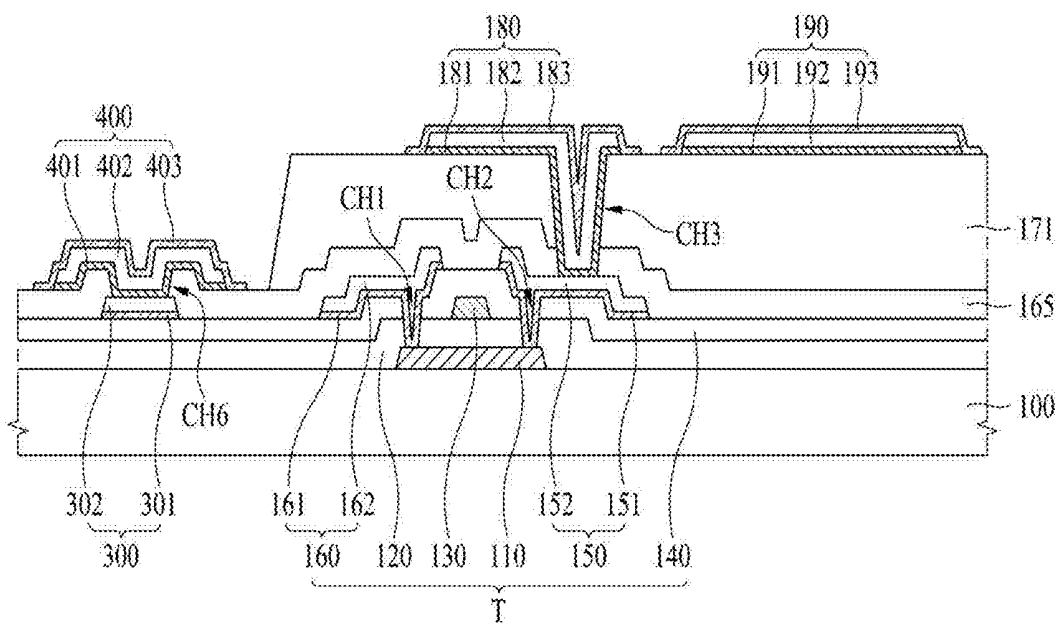

FIG. 1
(RELATED ART)

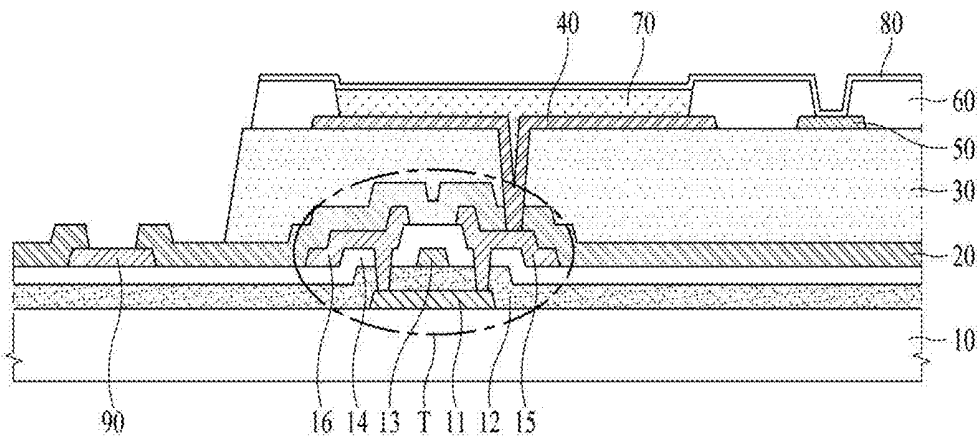

FIG. 2

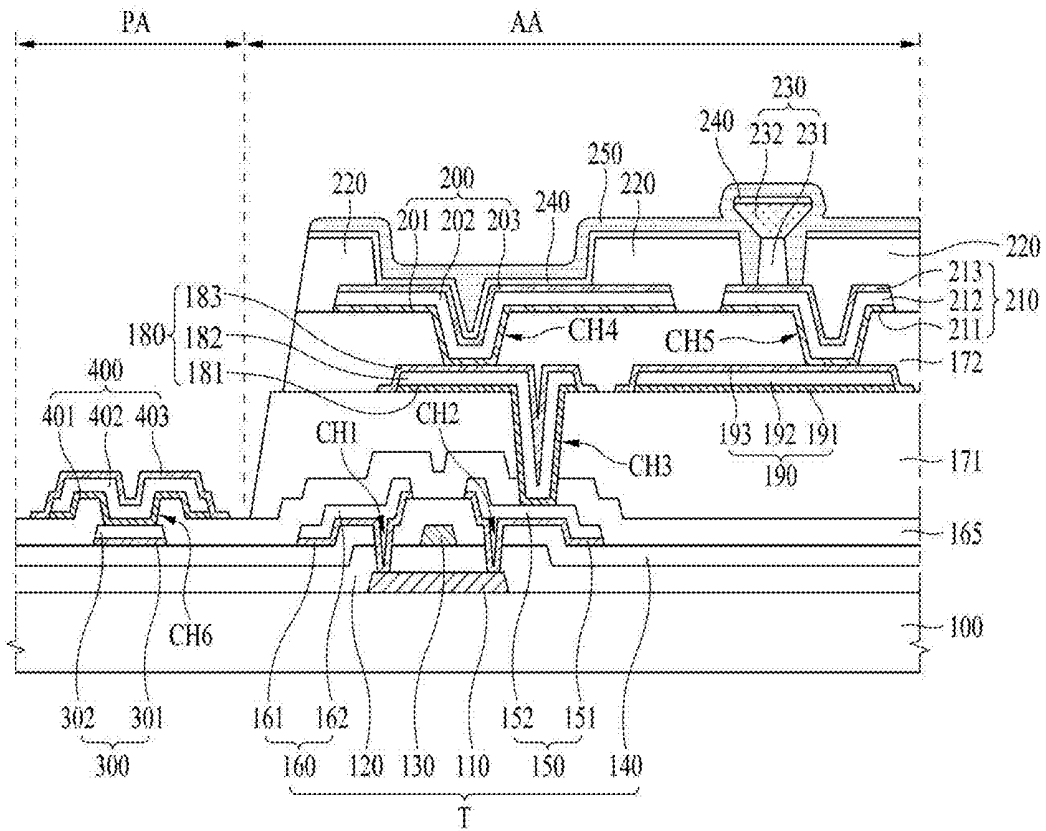

FIG. 3

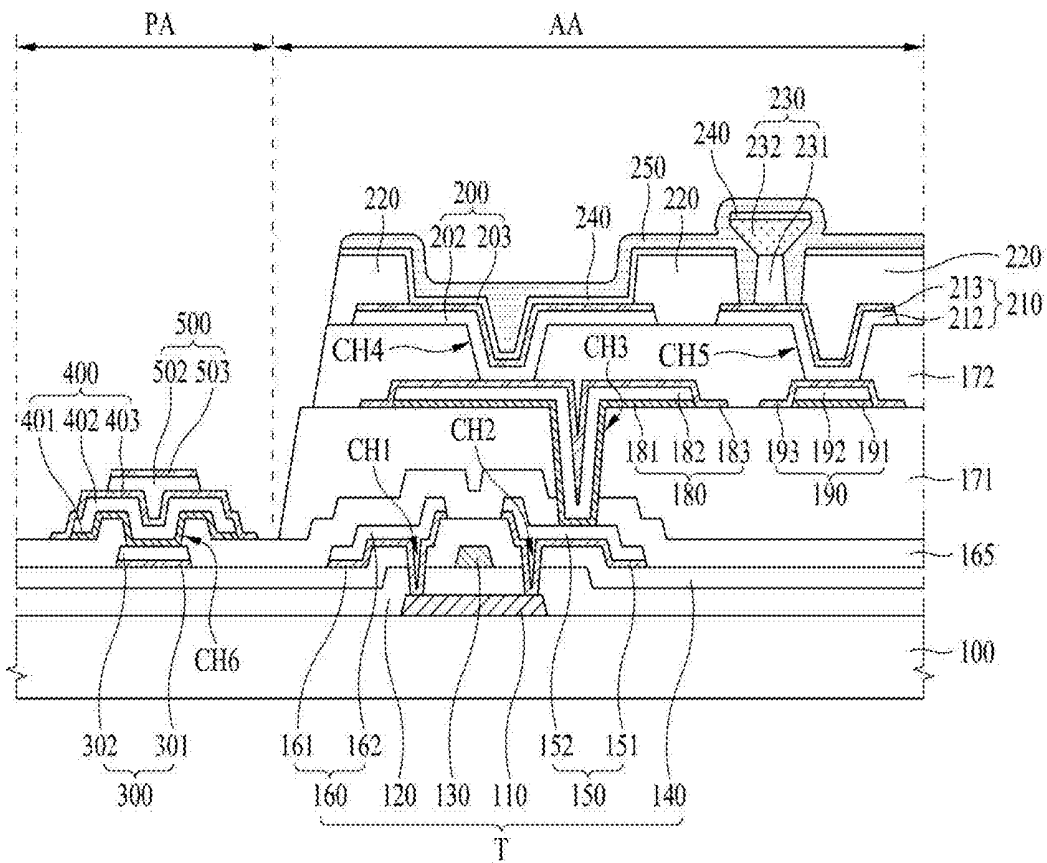

FIG. 4A

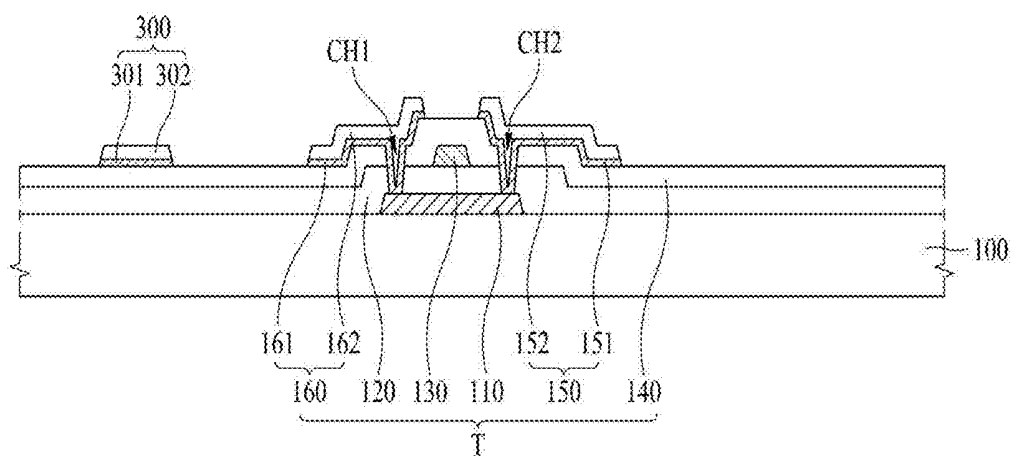

FIG. 4B

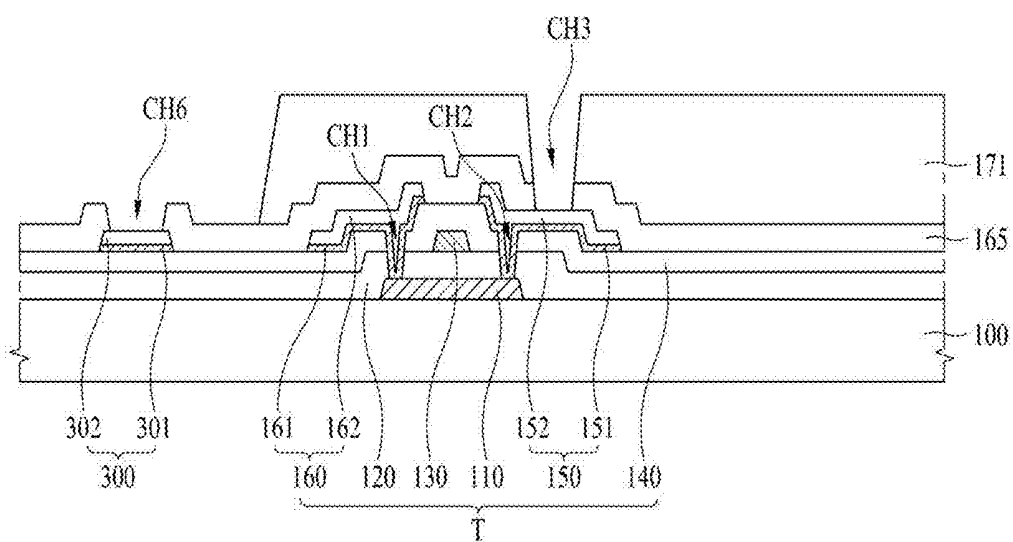

FIG. 4C

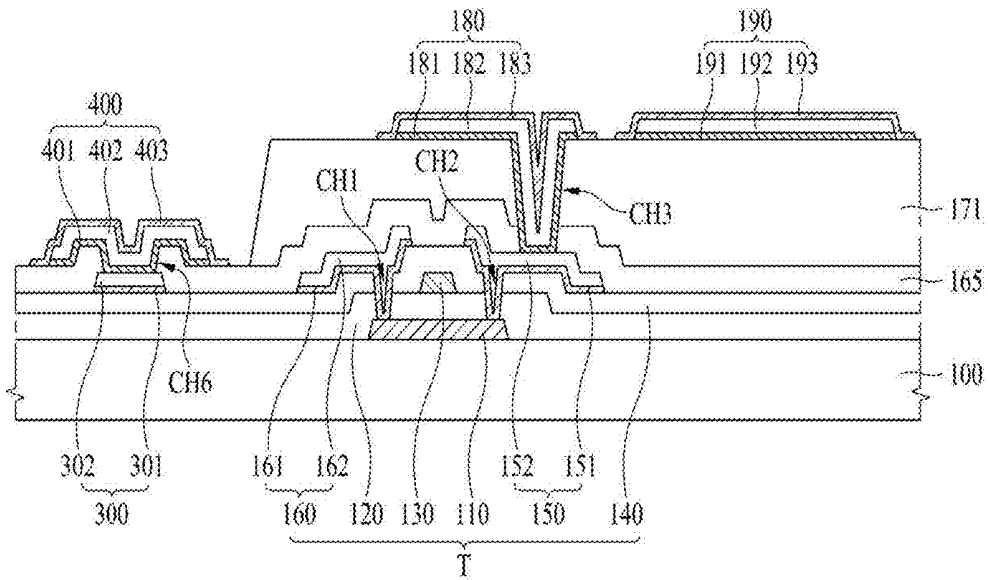

FIG. 4D

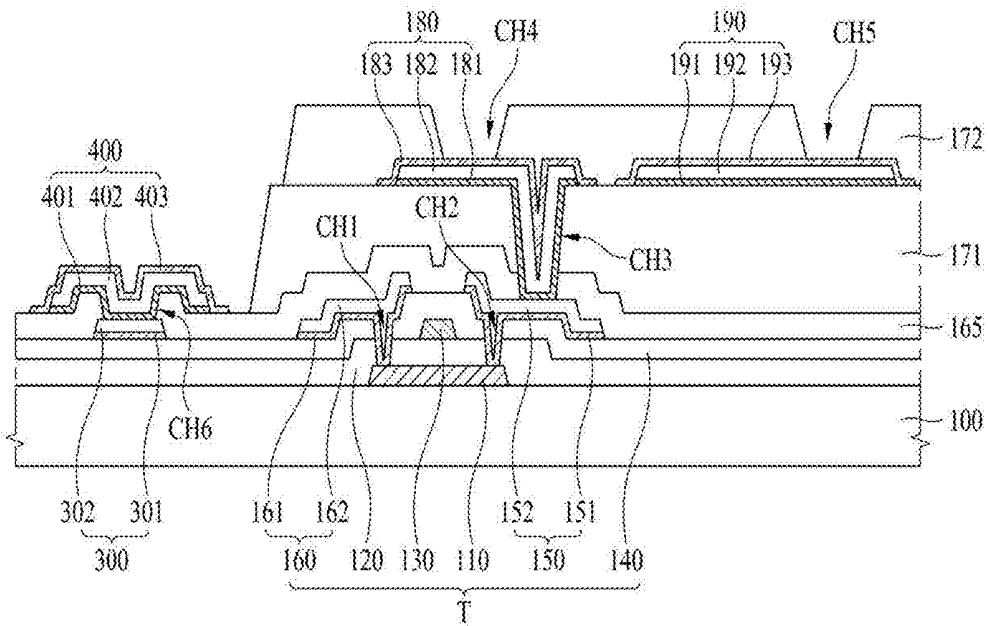

FIG. 4E

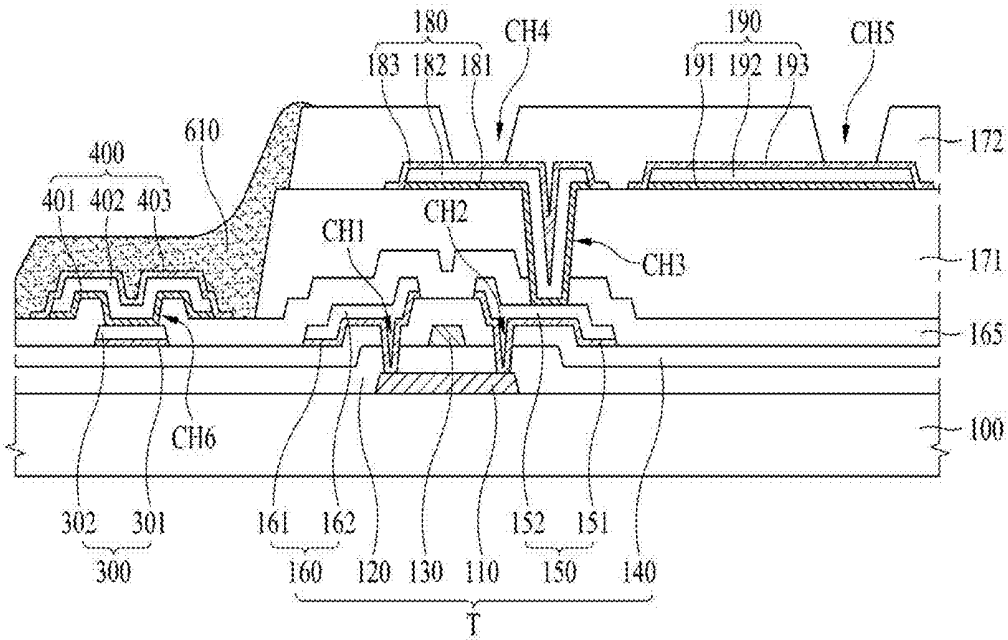

FIG. 4F

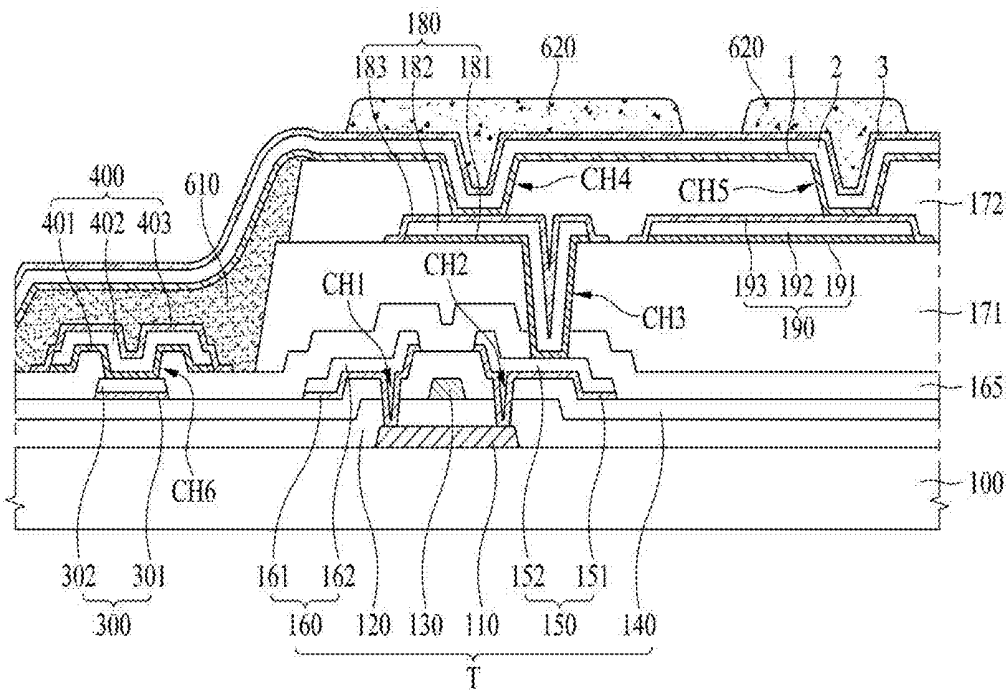

FIG. 4G

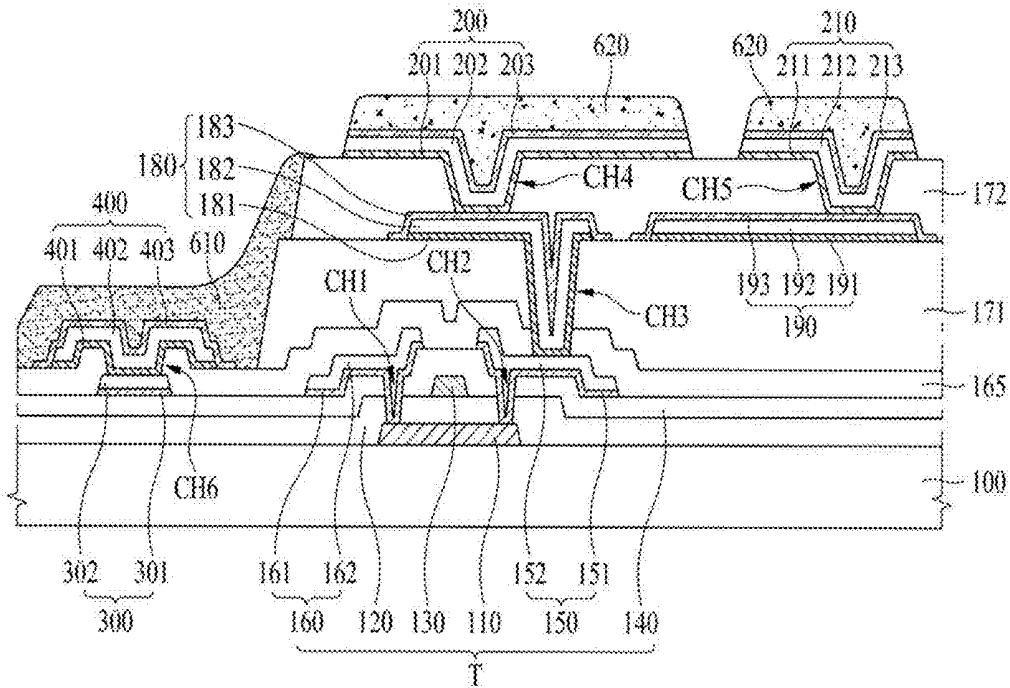

FIG. 4H

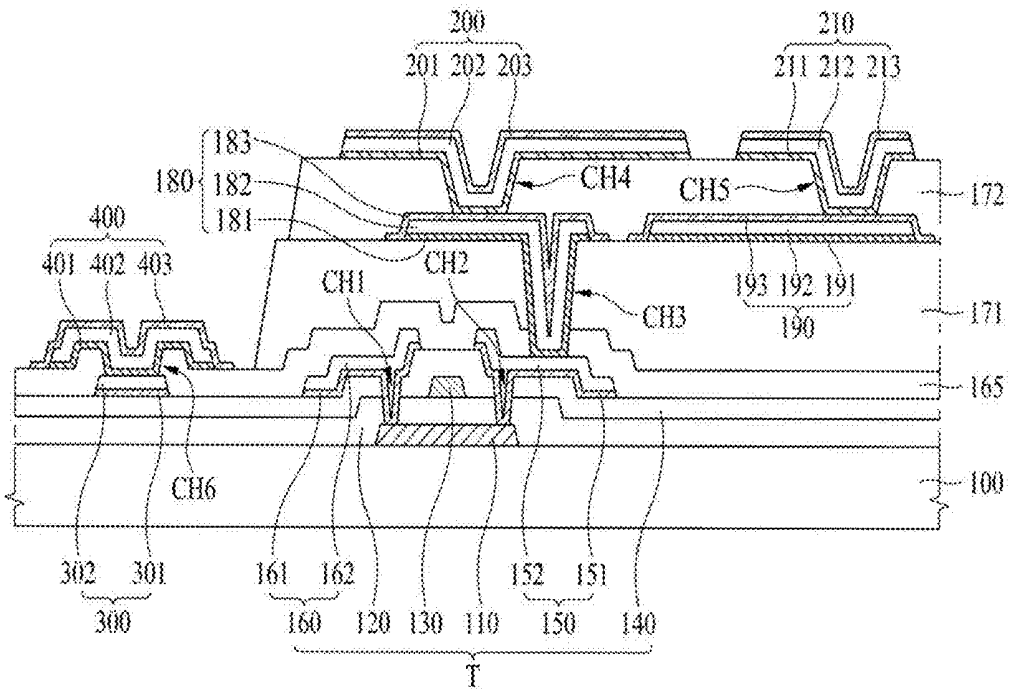

FIG. 4I

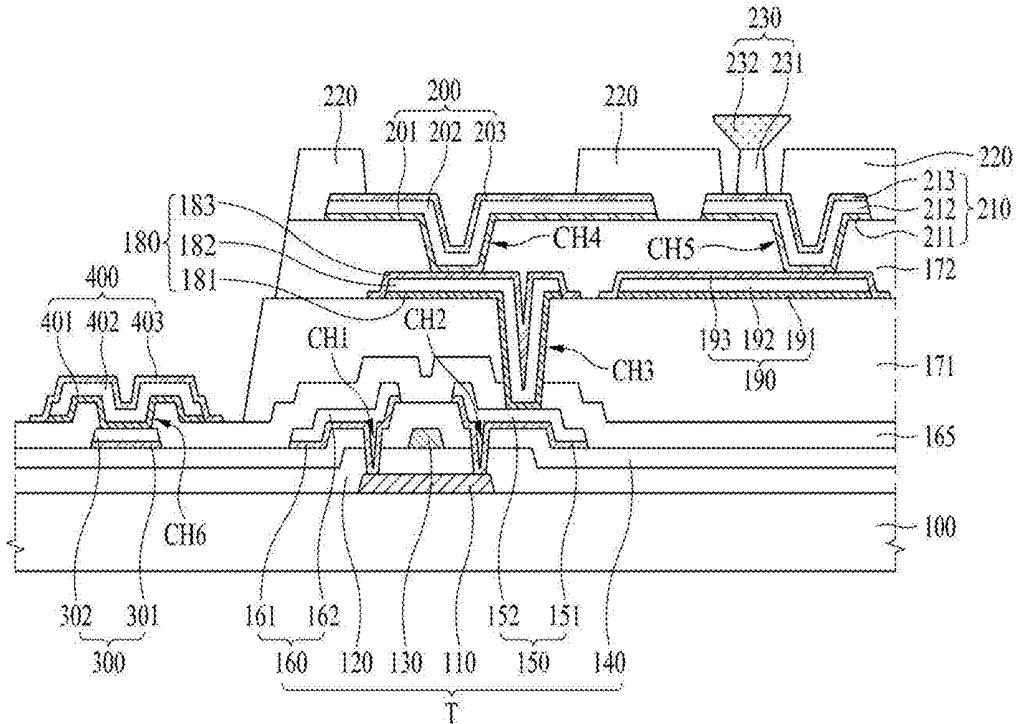

FIG. 4J

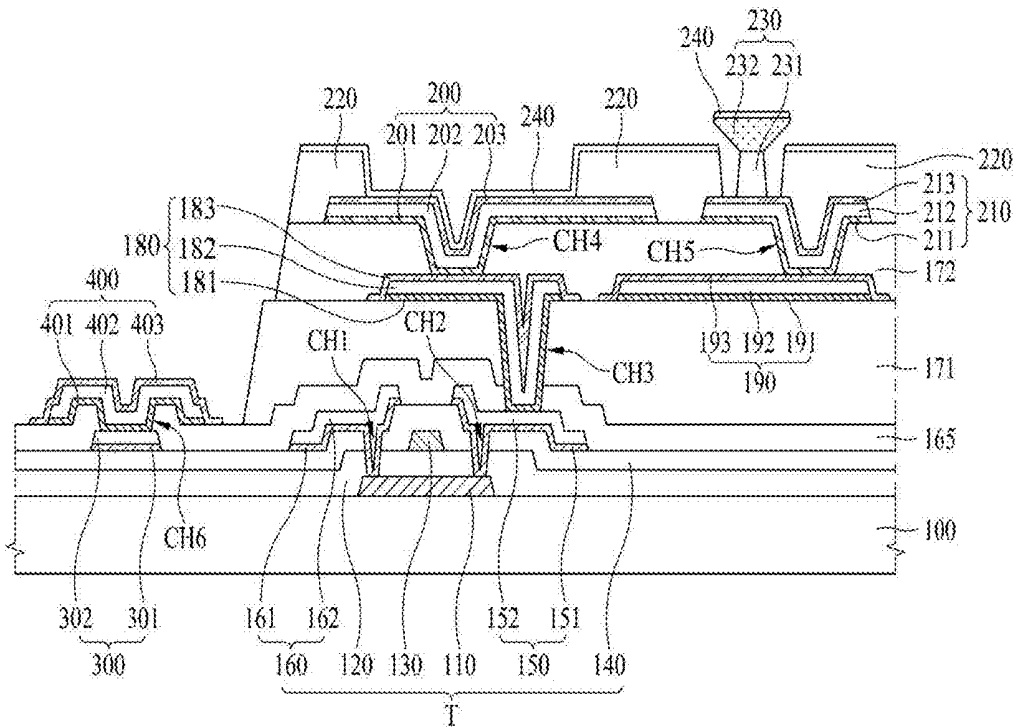

FIG. 4K

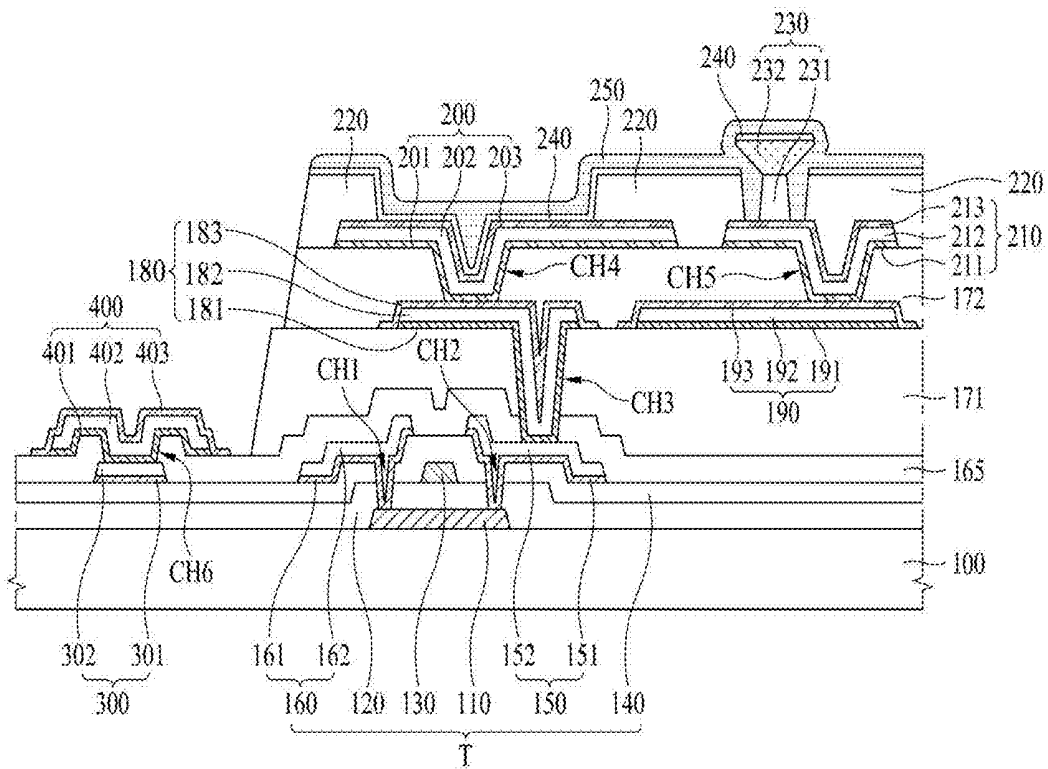

FIG. 5A

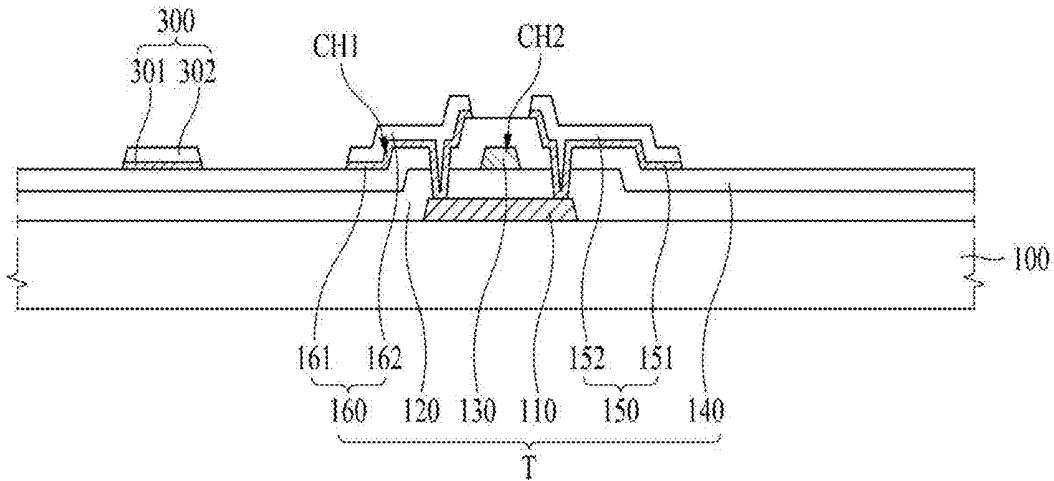

FIG. 5B

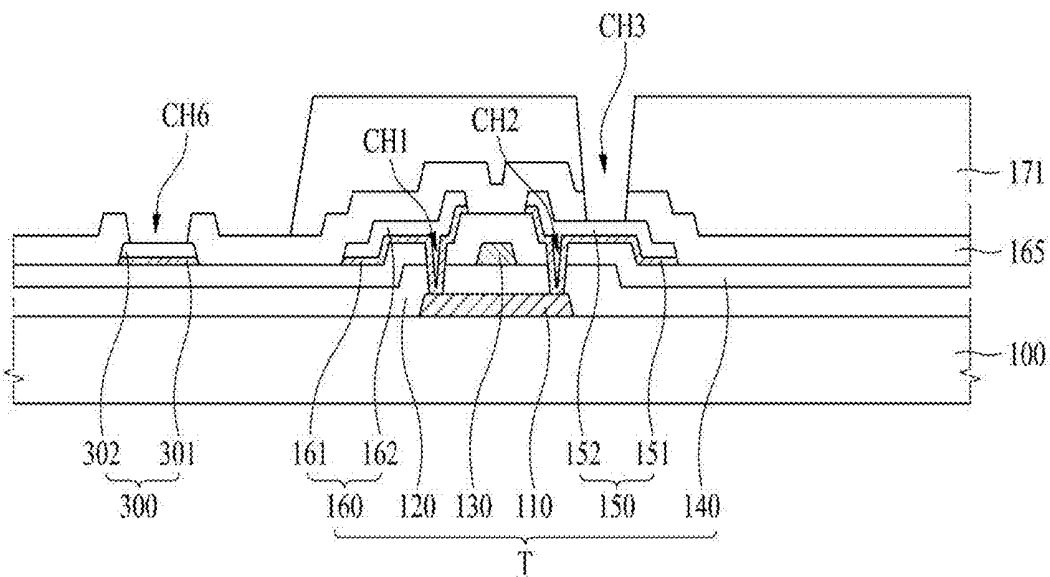

FIG. 5C

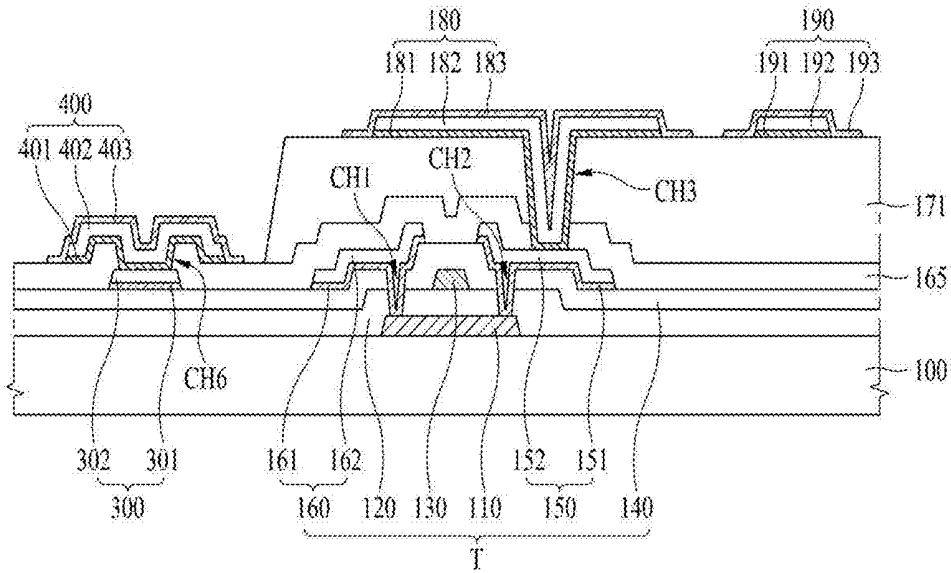

FIG. 5D

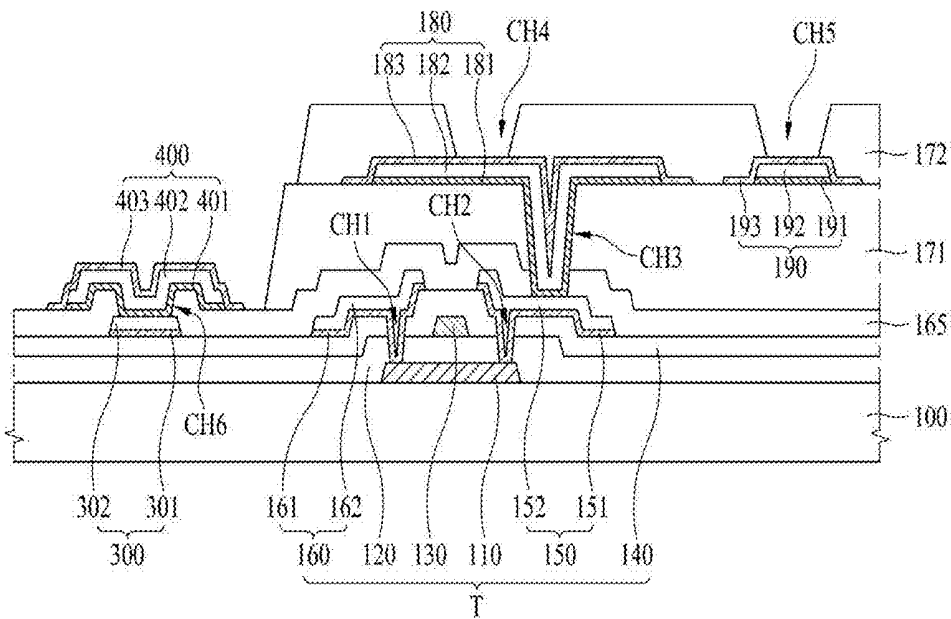

FIG. 5E

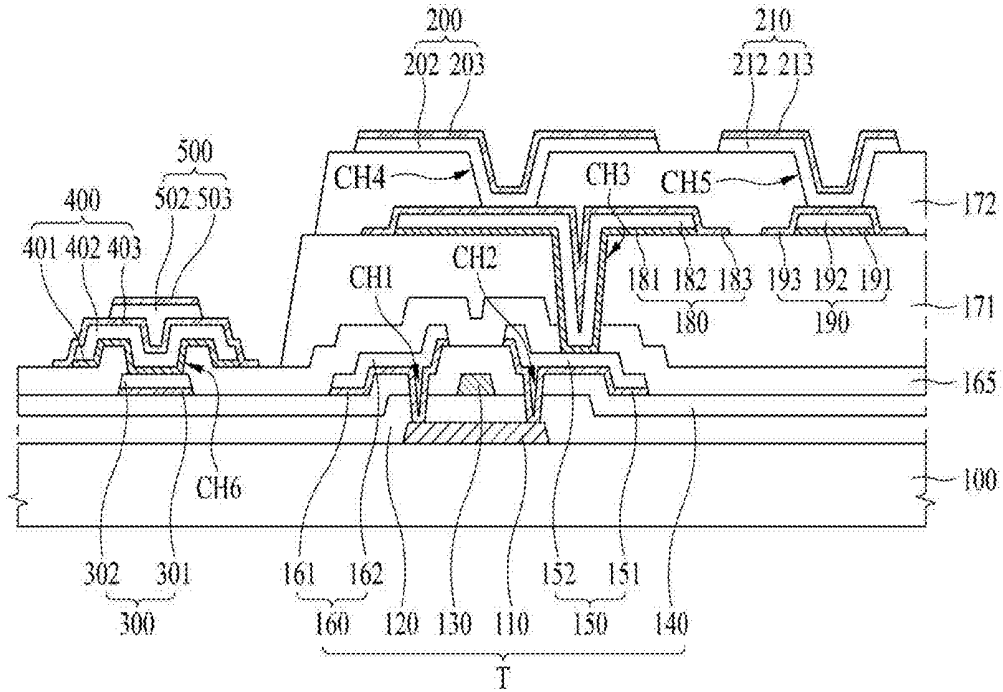
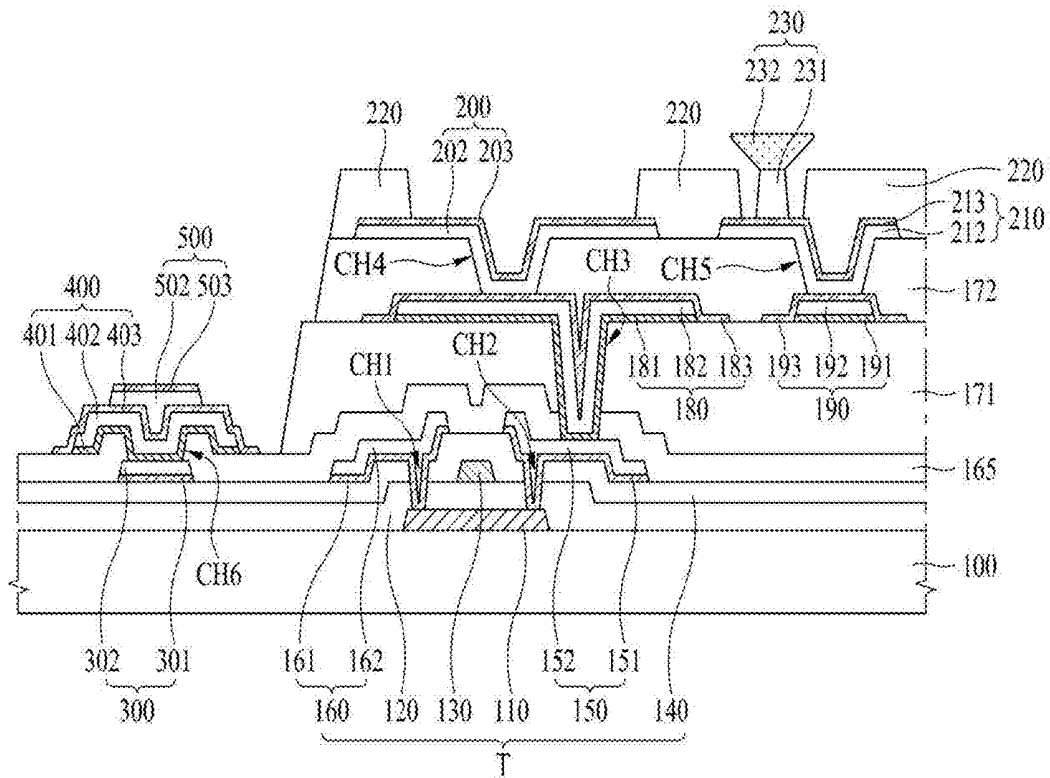

FIG. 5F



**ORGANIC LIGHT EMITTING DISPLAY
APPARATUS AND METHOD OF
MANUFACTURING THE SAME**

CROSS-REFERENCE TO RELATED
APPLICATION(S)

[0001] This application claims the benefit of Korean Patent Application No. 10-2015-0075397, filed on May 28, 2015, the entire disclosure of which is hereby incorporated by reference herein for all purposes.

BACKGROUND

1. Technical Field

[0002] The present disclosure relates to an organic light-emitting display apparatus, and, more particularly, to a top-emission type organic light-emitting display apparatus and a method of manufacturing the same.

2. Discussion of the Related Art

[0003] Organic light-emitting display apparatuses are self-emitting apparatuses and have low power consumption, a fast response time, high emission efficiency, high luminance, and a wide viewing angle. The organic light-emitting display apparatuses are classified into a top-emission type and a bottom-emission type, based on a transmission direction of light emitted from an organic light-emitting device. In the bottom-emission type organic light-emitting display apparatus, a circuit element is disposed between an emission layer and an image displaying surface, and for this reason, an aperture ratio is lowered. On the other hand, in the top-emission type organic light-emitting display apparatus, the circuit element is not disposed between the emission layer and the image displaying surface. Thus, an aperture ratio is enhanced.

[0004] FIG. 1 is a schematic cross-sectional view of a related art top-emission type organic light-emitting display apparatus.

[0005] As shown in FIG. 1, a thin film transistor (TFT) layer T that includes an active layer 11, a gate insulation layer 12, a gate electrode 13, an interlayer dielectric 14, a source electrode 15, and a drain electrode 16 is formed in an active area AA on a substrate 10. A passivation layer 20 and planarization layer 30 are sequentially formed on the TFT layer T.

[0006] An anode electrode 40 and an auxiliary electrode 50 are formed on the planarization layer 30. The auxiliary electrode 50 decreases a resistance of a cathode electrode 80, as will be described below.

[0007] A bank 60 is formed on the anode electrode 40 and the auxiliary electrode 50 and defines a pixel area. An organic emission layer 70 is formed in the pixel area defined by the bank 60, and the cathode electrode 80 is formed on the organic emission layer 70.

[0008] In the top-emission type organic light-emitting display apparatus, light emitted from the organic emission layer 70 passes through the cathode electrode 80. Therefore, the cathode electrode 80 is formed of a transparent conductive material, and a resistance of the cathode electrode 80 increases. To decrease the resistance of the cathode electrode 80, the cathode electrode 80 is connected to the auxiliary electrode 50.

[0009] The gate insulation layer 12 and the interlayer dielectric 14 are formed in a pad area PA on the substrate 10, a signal pad 90 is formed on the interlayer dielectric 14, and the passivation layer 20 is formed on the signal pad 90. A hole is provided in the passivation layer 20, and the signal pad 90 is exposed to the outside through the hole. Because the signal pad 90 should be connected to an external driving circuit, the signal pad 90 is exposed to the outside by forming the hole in the passivation layer 20.

[0010] The related art top-emission type organic light-emitting display apparatus has the following problems.

[0011] Because the signal pad 90 should be connected to the external driving circuit, a top of the signal pad 90 is exposed to the outside. For this reason, the top of the signal pad 90 is corroded, and the corrosion can spread to another area. A metal layer having excellent corrosion resistance may be further formed on the top of the signal pad 90 to prevent the top of the signal pad 90 from being corroded. However, in this case, the number of processes increases. Also, an electrode layer, which is the same as the anode electrode 40, may be formed on the signal pad 90 through the same process to prevent the top of the signal pad 90 from being corroded without an increase in number of processes. Even in this case, however, it is unable to prevent a material of the electrode material from being corroded, or it is unable to prevent corrosion from being spread through a side surface of the electrode layer.

[0012] Moreover, to connect the signal pad 90 to the external driving circuit, the top of the signal pad 90 is exposed by forming the hole in the passivation layer 20, but when the hole of the passivation layer 20 is previously formed, an etchant for pattern-forming the anode electrode 40 flows through the hole and damages the signal pad 90. To prevent the damage, a process of forming the hole of the passivation layer 20 for exposing the top of the signal pad 90 may be separately performed after a process of pattern-forming the anode electrode 40 is completed, but in this case, a separate (additional) mask process is added.

SUMMARY

[0013] Accordingly, the present disclosure is directed to an organic light-emitting display apparatus and a method of manufacturing the same that substantially obviate one or more of the problems due to limitations and disadvantages of the related art.

[0014] An object of the present disclosure is to provide a top-emission type organic light-emitting display apparatus and a method of manufacturing the same, in which the number of additional processes is minimized, and a signal pad is prevented from being corroded.

[0015] Additional features and advantages will be set forth in the description which follows, and in part will be apparent from the description, or may be learned by practice of the invention. The objectives and other advantages of the disclosure will be realized and attained by the structure particularly pointed out in the written description and claims thereof as well as the appended drawings.

[0016] To achieve these and other advantages and in accordance with the purpose of the present disclosure, as embodied and broadly described, there is provided an organic light-emitting display apparatus, including: a substrate including an active area and a pad area, an anode electrode in the active area of the substrate, an organic emission layer on the anode electrode, a cathode electrode

on the organic emission layer, an auxiliary electrode connected to the cathode electrode, a signal pad in the pad area of the substrate, and a first pad electrode connected to the signal pad, the first pad electrode covering a top of the signal pad, the first pad electrode being configured to prevent the top of the signal pad from being corroded, wherein the auxiliary electrode includes a first auxiliary electrode and a second auxiliary electrode connected to the first auxiliary electrode through a contact hole, and wherein the first pad electrode includes a same material as the first auxiliary electrode.

[0017] In another aspect, there is provided a method of manufacturing an organic light-emitting display apparatus, the method including: forming, on a substrate: a source electrode, a drain electrode, and a signal pad, forming a passivation layer on the source electrode, the drain electrode, and the signal pad, forming a first contact hole externally exposing the source electrode or the drain electrode by removing a predetermined region of the passivation layer, forming a second contact hole externally exposing the signal pad by removing another partial region of the passivation layer, forming a first anode electrode connected to the source electrode or the drain electrode, forming a first auxiliary electrode separated from the first anode electrode, forming a first pad electrode connected to the signal pad, the first pad electrode being formed of a same material as the first auxiliary electrode, forming a third contact hole externally exposing the first anode electrode, and forming a fourth contact hole externally exposing the first auxiliary electrode.

[0018] Other systems, methods, features and advantages will be, or will become, apparent to one with skill in the art upon examination of the following figures and detailed description. It is intended that all such additional systems, methods, features and advantages be included within this description, be within the scope of the present disclosure, and be protected by the following claims. Nothing in this section should be taken as a limitation on those claims. Further aspects and advantages are discussed below in conjunction with the embodiments. It is to be understood that both the foregoing general description and the following detailed description of the present disclosure are examples and explanatory, and are intended to provide further explanation of the disclosure as claimed.

BRIEF DESCRIPTION OF THE DRAWINGS

[0019] The accompanying drawings, which are included to provide a further understanding of the invention and are incorporated in and constitute a part of this specification, illustrate implementations of the invention and together with the description serve to explain the principles of the invention.

[0020] FIG. 1 is a schematic cross-sectional view of a related art top-emission type organic light-emitting display apparatus.

[0021] FIG. 2 is a cross-sectional view of an organic light-emitting display apparatus according to an example embodiment of the present disclosure.

[0022] FIG. 3 is a cross-sectional view of an organic light-emitting display apparatus according to an example embodiment of the present disclosure.

[0023] FIGS. 4A to 4K are cross-sectional views illustrating a method of manufacturing an organic light-emitting display apparatus according to an example embodiment of the present disclosure.

[0024] FIGS. 5A to 5H are cross-sectional views illustrating a method of manufacturing an organic light-emitting display apparatus according to an example embodiment of the present disclosure.

[0025] Throughout the drawings and the detailed description, unless otherwise described, the same drawing reference numerals should be understood to refer to the same elements, features, and structures. The relative size and depiction of these elements may be exaggerated for clarity, illustration, and convenience.

DETAILED DESCRIPTION

[0026] Reference will now be made in detail to embodiments of the present disclosure, examples of which are illustrated in the accompanying drawings. In the following description, when a detailed description of well-known functions or configurations related to this document is determined to unnecessarily cloud a gist of the invention, the detailed description thereof will be omitted. The progression of processing steps and/or operations described is an example; however, the sequence of steps and/or operations is not limited to that set forth herein and may be changed as is known in the art, with the exception of steps and/or operations necessarily occurring in a certain order. Like reference numerals designate like elements throughout. Names of the respective elements used in the following explanations are selected only for convenience of writing the specification and may be thus different from those used in actual products.

[0027] In the description of embodiments, when a structure is described as being positioned “on or above” or “under or below” another structure, this description should be construed as including a case in which the structures contact each other as well as a case in which a third structure is disposed therebetween.

[0028] Hereinafter, example embodiments of the present disclosure will be described in detail with reference to the accompanying drawings.

[0029] FIG. 2 is a cross-sectional view of an organic light-emitting display apparatus according to an example embodiment of the present disclosure.

[0030] As shown in FIG. 2, the organic light-emitting display apparatus according to an example embodiment of the present disclosure may include an active area AA and a pad area PA which are included in a substrate 100. A thin film transistor (TFT) T, a passivation layer 165, a first planarization layer 171, a second planarization layer 172, a first anode electrode 180, a second anode electrode 200, a first auxiliary electrode 190, a second auxiliary electrode 210, a bank 220, a partition wall 230, an organic emission layer 240, and a cathode electrode 250 may be formed in the active area AA of the substrate 100.

[0031] The TFT T may include an active layer 110, a gate insulation layer 120, a gate electrode 130, an interlayer dielectric 140, a source electrode 150, and a drain electrode 160. The active layer 110 may be formed on the substrate 100 to overlap the gate electrode 130. The active layer 110 may be formed of a silicon-based semiconductor material, or may be formed of an oxide-based semiconductor material. Although not shown, a light-shielding layer may be further

formed between the substrate **100** and the active layer **110**. For example, external light incident through a bottom of the substrate **100** may be blocked by the light shielding layer, thereby preventing the active layer **110** from being damaged by the external light.

[0032] The gate insulation layer **120** may be formed on the active layer **110**. The gate insulation layer **120** may insulate the active layer **110** from the gate electrode **130**. The gate insulation layer **120** may be formed of an inorganic insulating material, for example, silicon oxide (SiO_x), silicon nitride (SiN_x), or a multilayer thereof, but embodiments are not limited thereto. The gate insulation layer **120** may extend to the pad area PA.

[0033] The gate electrode **130** may be formed on the gate insulation layer **120**. The gate electrode **130** may be formed to overlap the active layer **110** with the gate insulation layer **120** therebetween. The gate electrode **130** may be formed of a single layer or a multilayer formed, for example, of one of molybdenum (Mo), aluminum (Al), chromium (Cr), gold (Au), titanium (Ti), nickel (Ni), neodymium (Nd), and copper (Cu) or an alloy thereof, but embodiments are not limited thereto.

[0034] The interlayer dielectric **140** may be formed on the gate electrode **130**. The interlayer dielectric **140** may be formed of the same inorganic insulating material as that of the gate insulation layer **120**, for example, silicon oxide (SiO_x), silicon nitride (SiN_x), or a multilayer thereof, but embodiments are not limited thereto. The interlayer dielectric **140** may extend to the pad area PA.

[0035] The source electrode **150** and the drain electrode **160** may be formed to face each other on the interlayer dielectric **140**. A first contact hole CH1 exposing one end region of the active layer **110** and a second contact hole CH2 exposing the other end region of the active layer **110** may be provided in the gate insulation layer **120** and the interlayer dielectric **140**. The source electrode **150** may be connected to the other end region of the active layer **110** through the second contact hole CH2, and the drain electrode **160** may be connected to the one end region of the active layer **110** through the first contact hole CH1.

[0036] The source electrode **150** may include a lower source electrode **151** and an upper source electrode **152**. The lower source electrode **151** may be formed between the interlayer dielectric **140** and the upper source electrode **152** and may enhance an adhesive force between the interlayer dielectric **140** and the upper source electrode **152**. Also, the lower source electrode **151** may protect a bottom of the upper source electrode **152**, thereby preventing the bottom of the upper source electrode **152** from being corroded. Therefore, an oxidation rate of the lower source electrode **151** may be lower than that of the upper source electrode **152**. That is, the lower source electrode **151** may be formed of a material that is stronger in corrosion resistance than a material forming the upper source electrode **152**. As described above, the lower source electrode **151** may act as an adhesion enhancement layer or an anti-corrosion layer and may be formed of an alloy (MoTi) of molybdenum (Mo) and titanium (Ti), but embodiments are not limited thereto.

[0037] The upper source electrode **152** may be formed on a top of the lower source electrode **151**. The upper source electrode **152** may be formed of copper (Cu), which is a metal having a low resistance, but embodiments are not limited thereto. The upper source electrode **152** may be formed of metal which is relatively lower in resistance than

the lower source electrode **151**. In order to lower a total resistance of the source electrode **150**, a thickness of the upper source electrode **152** may be formed thicker than that of the lower source electrode **151**.

[0038] Similarly to the above-described source electrode **150**, the drain electrode **160** may include a lower drain electrode **161** and an upper drain electrode **162**. The lower drain electrode **161** may be formed between the interlayer dielectric **140** and the upper drain electrode **162**. The lower drain electrode **161** may enhance an adhesive force between the interlayer dielectric **140** and the upper drain electrode **162**, and may also prevent a bottom of the upper drain electrode **162** from being corroded. Therefore, an oxidation rate of the lower drain electrode **161** may be lower than that of the upper drain electrode **162**. That is, the lower drain electrode **161** may be formed of a material having a stronger corrosion resistance than a material forming the upper drain electrode **162**. As described above, the lower drain electrode **161** may be formed of an alloy (MoTi) of molybdenum (Mo) and titanium (Ti), similarly to the above-described material of the lower source electrode **151**, but embodiments are not limited thereto.

[0039] The upper drain electrode **162** may be formed on top of the lower drain electrode **161** and may be formed of copper (Cu), similarly to the above-described material of the upper source electrode **152**, but embodiments are not limited thereto. The upper drain electrode **162** may be thicker than that of the lower drain electrode **161**, thereby lowering a total resistance of the drain electrode **160**.

[0040] The upper drain electrode **162** may be formed of the same material as that of the upper source electrode **152**, and may have the same thickness as that of the upper source electrode **152**, and the lower drain electrode **161** may be formed of the same material as that of the lower source electrode **151**, and may have the same thickness as that of the lower source electrode **151**. In some embodiments, the drain electrode **160** and the source electrode **150** may be simultaneously formed through the same process.

[0041] A structure of the TFT T is not limited to the illustrated structure, and may be variously modified to structures known to those skilled in the art. For example, a top gate structure in which the gate electrode **130** is formed on the active layer **110** is illustrated in the FIG. 2 example, but the TFT T may alternatively be formed in a bottom gate structure in which the gate electrode **130** is formed under the active layer **110**.

[0042] The passivation layer **165** may be formed on the TFT T, and, for example, may be formed on tops of the source electrode **150** and the drain electrode **160**. The passivation layer **165** protects the TFT T. The passivation layer **165** may be formed of an inorganic insulating material (for example, SiO_x and SiN_x), but embodiments are not limited thereto. The passivation layer **165** may extend to the pad area PA.

[0043] The first planarization layer **171** may be formed on the passivation layer **165**. The first planarization layer **171** may planarize an upper surface of the substrate **100** including the TFT T. The first planarization layer **171** may be formed of an organic insulating material, such as acrylic resin, epoxy resin, phenolic resin, polyamide resin, polyimide resin, or the like, but embodiments are not limited thereto. The first planarization layer **171** may not extend to the pad area PA.

[0044] The first anode electrode **180** and the first auxiliary electrode **190** may be formed on the first planarization layer **171**. That is, the first anode electrode **180** and the first auxiliary electrode **190** may be formed on the same layer. A third contact hole CH3 exposing the source electrode **150** may be provided in the passivation layer **165** and the first planarization layer **171**, and the source electrode **150** may be connected to the first anode electrode **180** through the third contact hole CH3. In some embodiments, the first anode electrode **180** may be connected with the source electrode **150**. However, the source electrode **150** and the drain electrode **160** can be switched based on the mode of the transistor. Accordingly, in some embodiments, the first anode electrode **180** may be connected with the drain electrode **160** instead of the source electrode **150**. As a result, the first anode electrode **180** may be connected with the source electrode **150** or the drain electrode **160**.

[0045] The first anode electrode **180** may include a first lower anode electrode **181**, a first upper anode electrode **182**, and a first cover anode electrode **183**. The first lower anode electrode **181** may be formed between the first planarization layer **171** and the first upper anode electrode **182**, and may enhance an adhesive force between the first planarization layer **171** and the first upper anode electrode **182**. Also, the first lower anode electrode **181** may protect a bottom of the first upper anode electrode **182**, thereby preventing the bottom of the first upper anode electrode **182** from being corroded. Therefore, an oxidation rate of the first lower anode electrode **181** may be lower than that of the first upper anode electrode **182**. That is, the first lower anode electrode **181** may be formed of a material having a stronger corrosion resistance than a material forming the first upper anode electrode **182**. Also, the first lower anode electrode **181** may protect a top of the upper source electrode **152**, thereby preventing the top of the upper source electrode **152** from being corroded. Therefore, an oxidation rate of the first lower anode electrode **181** may be lower than that of the upper source electrode **152**. That is, the first lower anode electrode **181** may be formed of a material having a stronger corrosion resistance than a material forming the upper source electrode **152**. As described above, the first lower anode electrode **181** may prevent the top of the upper source electrode **152** from being corroded. Thus, the source electrode **150** may be formed in the above-described two-layer structure. The first lower anode electrode **181** may act as an adhesion enhancement layer or an anti-corrosion layer and may be formed of an alloy (MoTi) of molybdenum (Mo) and titanium (Ti), but embodiments are not limited thereto.

[0046] The first upper anode electrode **182** may be formed between the first lower anode electrode **181** and the first cover anode electrode **183**. The first upper anode electrode **182** may be formed of copper (Cu), which is a metal having a low resistance, but embodiments are not limited thereto. The first upper anode electrode **182** may be formed of metal which is relatively lower in resistance than the first lower anode electrode **181**. To lower a total resistance of the first anode electrode **180**, the first upper anode electrode **182** may be thicker than that of each of the first lower anode electrode **181** and the first cover anode electrode **183**.

[0047] The first cover anode electrode **183** may be formed on the first upper anode electrode **182**. The first cover anode electrode **183** may be formed to cover a top and a side surface of the first upper anode electrode **182**, thereby preventing the first upper anode electrode **182** from being

corroded. To this end, an oxidation rate of the first cover anode electrode **183** may be lower than that of the first upper anode electrode **182**. That is, the first cover anode electrode **183** may be formed of a material having a stronger corrosion resistance than a material forming the first upper anode electrode **182**.

[0048] The first cover anode electrode **183** may cover up to a side surface of the first lower anode electrode **181**. In such a case, an oxidation rate of the first cover anode electrode **183** may be lower than that of the first lower anode electrode **181**. That is, the first cover anode electrode **183** may be formed of a material having a stronger corrosion resistance than a material forming the first lower anode electrode **181**. The first cover anode electrode **183** may be formed of a transparent conductive material, such as indium tin oxide (ITO) or the like, but embodiments are not limited thereto.

[0049] Similarly to the above-described first anode electrode **180**, the first auxiliary electrode **190** may include a first lower auxiliary electrode **191**, a first upper auxiliary electrode **192**, and a first cover auxiliary electrode **193**. The first lower auxiliary electrode **191** may be formed between the first planarization layer **171** and the first upper auxiliary electrode **192**. The first lower auxiliary electrode **191** may enhance an adhesive force between the first planarization layer **171** and the first upper auxiliary electrode **192**, and may also prevent a bottom of the first upper auxiliary electrode **192** from being corroded. Therefore, an oxidation rate of the first lower auxiliary electrode **191** may be lower than that of the first upper auxiliary electrode **192**. That is, the first lower auxiliary electrode **191** may be formed of a material having a stronger corrosion resistance than a material forming the first upper auxiliary electrode **192**. As described above, the first lower auxiliary electrode **191** may be formed of an alloy (MoTi) of molybdenum (Mo) and titanium (Ti), which is similar to the above-described material of the first lower anode electrode **181**, but embodiments are not limited thereto.

[0050] The first upper auxiliary electrode **192** may be formed between the first lower auxiliary electrode **191** and the first cover auxiliary electrode **193** and may be formed of copper (Cu), which is similar to the above-described material of the first upper anode electrode **182**, but embodiments are not limited thereto. The first upper auxiliary electrode **192** (which has a relatively low resistance) may be thicker than that of each of the first lower auxiliary electrode **191** and the first cover auxiliary electrode **193** (which have relatively high resistances), thereby lowering a total resistance of the first auxiliary electrode **190**.

[0051] The first cover auxiliary electrode **193** may be formed on the first upper auxiliary electrode **192**. The first cover auxiliary electrode **193** may be formed to cover a top and a side surface of the first upper auxiliary electrode **192**, thereby preventing the first upper auxiliary electrode **192** from being corroded. To this end, an oxidation rate of the first cover auxiliary electrode **193** may be lower than that of the first upper auxiliary electrode **192**. That is, the first cover auxiliary electrode **193** may be formed of a material having a stronger corrosion resistance than a material forming the first upper auxiliary electrode **192**.

[0052] The first cover auxiliary electrode **193** may cover up to a side surface of the first lower auxiliary electrode **191**. In this case, an oxidation rate of the first cover auxiliary electrode **193** may be lower than that of the first lower

auxiliary electrode **191**. That is, the first cover auxiliary electrode **193** may be formed of a material having a stronger corrosion resistance than a material forming the first lower auxiliary electrode **191**. The first cover auxiliary electrode **193** may be formed of a transparent conductive material, such as ITO or the like, but embodiments are not limited thereto.

[0053] The first cover auxiliary electrode **193** may be formed of the same material as that of the first cover anode electrode **183**, and may have the same thickness as that of the first cover anode electrode **183**. The first upper auxiliary electrode **192** may be formed of the same material as that of the first upper anode electrode **182**, and may have the same thickness as that of the first upper anode electrode **182**. The first lower auxiliary electrode **191** may be formed of the same material as that of the first lower anode electrode **181**, and may have the same thickness as that of the first lower anode electrode **181**. In some embodiments, the first auxiliary electrode **190** and the first anode electrode **180** may be formed simultaneously through the same process.

[0054] The second planarization layer **172** may be formed on the first auxiliary electrode **190** and the first anode electrode **180**. The second planarization layer **172** may planarize an upper surface of the substrate **100** along with the above-described first planarization layer **171**. The second planarization layer **172** may be formed of an organic insulating material, such as acryl resin, epoxy resin, phenolic resin, polyamide resin, polyimide resin, or the like, but embodiments are not limited thereto. The second planarization layer **172** may not extend to the pad area PA.

[0055] A fourth contact hole CH4 and a fifth contact hole CH5 may be included in the second planarization layer **172**. The first anode electrode **180** may be exposed by the fourth contact hole CH4, and the first auxiliary electrode **190** may be exposed by the fifth contact hole CH5.

[0056] The second anode electrode **200** may be formed on the second planarization layer **172**. The second anode electrode **200** may be connected to the first anode electrode **180** through the fourth contact hole CH4. The second anode electrode **200** may reflect light, emitted from the organic emission layer **240**, in an upward direction, and the second anode electrode **200** may be formed of a highly reflective material.

[0057] The second anode electrode **200** may include a second lower anode electrode **201**, a second center anode electrode **202**, and a second upper anode electrode **203**. The second lower anode electrode **201** may be formed between the first anode electrode **180** and the second center anode electrode **202**. The second lower anode electrode **201** may protect a bottom of the second center anode electrode **202**, thereby preventing the bottom of the second center anode electrode **202** from being corroded. An oxidation rate of the second lower anode electrode **201** may be lower than that of the second center anode electrode **202**. That is, the second lower anode electrode **201** may be formed of a material having a stronger corrosion resistance than a material forming the second center anode electrode **202**. The second lower anode electrode **201** may be formed of a transparent conductive material, such as ITO or the like, but embodiments are not limited thereto.

[0058] The second center anode electrode **202** may be formed between the second lower anode electrode **201** and the second upper anode electrode **203**. The second center anode electrode **202** may be formed of a material having a

lower resistance and a better reflectivity than the second lower anode electrode **201** and the second upper anode electrode **203**. For example, the second center anode electrode **202** may be formed of silver (Ag). However, embodiments are not limited thereto. A thickness of the second center anode electrode **202** (which has a relatively low resistance) may be formed thicker than that of each of the second lower anode electrode **201** and the second upper anode electrode **203** (which have relatively high resistances), thereby lowering a total resistance of the second anode electrode **200**.

[0059] The second upper anode electrode **203** may be formed on a top of the second center anode electrode **202**, thereby preventing the top of the second center anode electrode **202** from being corroded. To this end, an oxidation rate of the second upper anode electrode **203** may be lower than that of the second center anode electrode **202**. That is, the second upper anode electrode **203** may be formed of a material having a stronger corrosion resistance than a material forming the second center anode electrode **202**. The second upper anode electrode **203** may be formed of a transparent conductive material, such as ITO or the like, but embodiments are not limited thereto.

[0060] The second auxiliary electrode **210** may be formed on the second planarization layer **172** identically to the second anode electrode **200**. The second auxiliary electrode **210** may be connected to the first auxiliary electrode **190** through the fifth contact hole CH5. The second auxiliary electrode **210** may lower a resistance of the cathode electrode **250** along with the first auxiliary electrode **190**.

[0061] The second auxiliary electrode **210** may include a second lower auxiliary electrode **211**, a second center auxiliary electrode **212**, and a second upper auxiliary electrode **213**. The second lower auxiliary electrode **211** may be formed between the first auxiliary electrode **190** and the second center auxiliary electrode **212**. The second lower auxiliary electrode **211** may protect a bottom of the second center auxiliary electrode **212**, thereby preventing the bottom of the second center auxiliary electrode **212** from being corroded. To this end, an oxidation rate of the second lower auxiliary electrode **211** may be lower than that of the second center auxiliary electrode **212**. That is, the second lower auxiliary electrode **211** may be formed of a material having a stronger corrosion resistance than a material forming the second center auxiliary electrode **212**. The second lower auxiliary electrode **211** may be formed of a transparent conductive material, such as ITO or the like, but embodiments are not limited thereto.

[0062] The second center auxiliary electrode **212** may be formed between the second lower auxiliary electrode **211** and the second upper auxiliary electrode **213**. The second center auxiliary electrode **212** may be formed of a material which having a lower resistance and a better reflectivity than the second lower auxiliary electrode **211** and the second upper auxiliary electrode **213**, and for example, may be formed of silver (Ag). However, the present embodiment is not limited thereto. A thickness of the second center auxiliary electrode **212** which is relatively low in resistance may be formed thicker than that of each of the second lower auxiliary electrode **211** and the second upper auxiliary electrode **213** which are relatively high in resistance, thereby lowering a total resistance of the second auxiliary electrode **210**.

[0063] The second upper auxiliary electrode **213** may be formed on a top of the second center auxiliary electrode **212**, thereby preventing the top of the second center auxiliary electrode **212** from being corroded. To this end, an oxidation rate of the second upper auxiliary electrode **213** may be lower than that of the second center auxiliary electrode **212**. That is, the second upper auxiliary electrode **213** may be formed of a material having a stronger corrosion resistance than a material forming the second center auxiliary electrode **212**. The second upper auxiliary electrode **213** may be formed of a transparent conductive material, such as ITO or the like, but embodiments are not limited thereto.

[0064] The second upper auxiliary electrode **213** may be formed of the same material as that of the second upper anode electrode **203**, and may have the same thickness as that of the second upper anode electrode **203**. The second center auxiliary electrode **212** may be formed of the same material as that of the second center anode electrode **202**, and may have the same thickness as that of the second center anode electrode **202**. The second lower auxiliary electrode **211** may be formed of the same material as that of the second lower anode electrode **201**, and may have the same thickness as that of the second lower anode electrode **201**. In some embodiments, the second auxiliary electrode **210** and the second anode electrode **200** may be simultaneously formed through the same process.

[0065] According to an embodiment of the present disclosure, two auxiliary electrodes (for example, the first and second auxiliary electrodes **190** and **210**) connected to each other may be formed for lowering the resistance of the cathode electrode **250**. Thus, the desired resistance characteristic of an auxiliary electrode may be more easily adjusted.

[0066] Because the second auxiliary electrode **210** may be formed on the same layer as a layer on which the second anode electrode **200** is disposed, a width of the second anode electrode **200** may be reduced when a width of the second auxiliary electrode **210** increases. In this case, a pixel area of a display apparatus may be reduced. As such, there may be a limitation in increasing the width of the second auxiliary electrode **210**. Therefore, according to an embodiment of the present disclosure, the first auxiliary electrode **190** connected to the second auxiliary electrode **210** may be further formed under the second auxiliary electrode **210**. Thus, the resistance of the cathode electrode **150** may be effectively lowered, even without any reduction in a pixel area.

[0067] The first auxiliary electrode **190** may be formed on the same layer as a layer on which the first anode electrode **180** is disposed. Because the first anode electrode **180** may connect the source electrode **150** to the second anode electrode **200**, a width of the first anode electrode **180** may be reduced, thereby increasing a width of the first auxiliary electrode **190**. That is, the width of the first auxiliary electrode **190** may be formed greater than that of the first anode electrode **180**. In addition, the width of first auxiliary electrode **190** may increase so the first auxiliary electrode **190** may overlap the second anode electrode **200**, whereby the resistance of the cathode electrode **150** may be more effectively lowered.

[0068] The bank **220** may be formed on the second anode electrode **200** and the second auxiliary electrode **210**. The bank **220** may be formed on one side and the other side (e.g., both sides) of the second anode electrode **200** to expose a top of the second anode electrode **200**. Because the bank **220**

may be formed to expose the top of the second anode electrode **200**, an area where an image is displayed may be secured. Also, because the bank **220** may be formed on the one side and the other side of the second anode electrode **200**, a side surface of the second center anode electrode **202** vulnerable to corrosion may be prevented from being exposed to the outside, thereby preventing the side surface of the second center anode electrode **202** from being corroded.

[0069] The bank **220** may be formed on one side and the other side (e.g., on both sides) of the second auxiliary electrode **210** to expose a top of the second auxiliary electrode **210**. Because the bank **220** may be formed to expose the top of the second auxiliary electrode **210**, an electrical connection space between the second auxiliary electrode **210** and the cathode electrode **250** may be secured. Also, because the bank **220** may be formed on the one side and the other side of the second auxiliary electrode **210**, a side surface of the second center auxiliary electrode **212** vulnerable to corrosion may be prevented from being exposed to the outside, thereby preventing the side surface of the second center auxiliary electrode **212** from being corroded.

[0070] Moreover, the bank **220** may be formed between the second anode electrode **200** and the second auxiliary electrode **210**, and may insulate the second anode electrode **200** from the second auxiliary electrode **210**. The bank **220** may be formed of an organic insulating material, such as polyimide resin, acryl resin, benzocyclobutene (BCB), or the like, but embodiments are not limited thereto.

[0071] The partition wall **230** may be formed on the second auxiliary electrode **210**. The partition wall **230** may be separated from the bank **220** by a certain distance, and the second auxiliary electrode **210** may be electrically connected to the cathode electrode **250** through a separation space between the partition wall **230** and the bank **220**. The second auxiliary electrode **210** may be electrically connected to the cathode electrode **250** without forming the partition wall **230**. However, if the partition wall **230** is formed, the organic emission layer **240** may be more easily deposition-formed. The formation of the partition wall **230** will be described below in more detail.

[0072] If the partition wall **230** is not formed, a mask pattern that covers a top of the second auxiliary electrode **210** may be used in depositing the organic emission layer **240**, so that the top of the second auxiliary electrode **210** may not be covered by the organic emission layer **240**. However, if the partition wall **230** is formed, a top of the partition wall **230** may act as an eaves shape or overhang in depositing the organic emission layer **240**. Thus, because the organic emission layer **240** may not be deposited under the eaves, the mask pattern which covers the top of the second auxiliary electrode **210** may not be needed. That is, in a front view of an example of the organic light-emitting display apparatus, when the top of the partition wall **230** that acts as eaves is formed to cover a separation space between the partition wall **230** and the bank **220**, the organic emission layer **240** may not penetrate into the separation space between the partition wall **230** and the bank **220**. Thus, the second auxiliary electrode **210** may be exposed in the separation space between the partition wall **230** and the bank **220**. For example, the organic emission layer **240** may be formed by a deposition process, such as an evaporation process, which may be excellent in terms of accuracy and

straightness of deposition of a deposited material. However, embodiments are not limited thereto. Thus, the organic emission layer 240 may not be deposited in the separation space between the partition wall 230 and the bank 220.

[0073] As described above, a width of the top of the partition wall 230 may be greater than that of a bottom of the partition wall 230, such that the top of the partition wall 230 may act as the eaves. The partition wall 230 may include a lower first partition wall 231 and an upper second partition wall 232. The first partition wall 231 may be formed on a top of the second auxiliary electrode 210, and may be formed of the same material as that of the bank 220, may be formed through the same process as that of the bank 220. The second partition wall 232 may be formed on a top of the first partition wall 231. A width of a top of the second partition wall 232 may be formed greater than that of a bottom of the second partition wall 232. For example, the top of the second partition wall 232 may be formed to cover the separation space between the partition wall 230 and the bank 220, and may act as eaves.

[0074] The organic emission layer 240 may be formed on the second anode electrode 200. The organic emission layer 240 may include a hole injection layer, a hole transport layer, an emission layer, an electron transport layer, and an electron injection layer. The organic emission layer 240 may be modified to have various structures known to those skilled in the art.

[0075] The organic emission layer 240 may extend to the top of the bank 220. However, the organic emission layer 240 may not extend to the top of the second auxiliary electrode 210 to cover the top of the second auxiliary electrode 210. This is because, if the organic emission layer 240 covers the top of the second auxiliary electrode 210, it may be difficult to electrically connect the second auxiliary electrode 210 to the cathode electrode 250. As described above, the organic emission layer 240 may be formed by a deposition process without a mask that covers the top of the second auxiliary electrode 210. For example, the organic emission layer 240 may be formed on the top of the partition wall 230.

[0076] The cathode electrode 250 may be formed on the organic emission layer 240. The cathode electrode 250 may be formed on a surface from which light is emitted, and thus may be formed of a transparent conductive material. Because the cathode electrode 250 may be formed of a transparent conductive material, a resistance of the cathode electrode 250 may be high. For example, in order to lower the resistance of the cathode electrode 250, the cathode electrode 250 may be connected to the second auxiliary electrode 210. Also, the cathode electrode 250 may be connected to the second auxiliary electrode 210 through the separation space between the partition wall 230 and the bank 220. The cathode electrode 250 may be formed by a deposition process, such as a sputtering process, which may not be as accurate or provide as much straightness of deposition of a deposited material. However, embodiments are not limited thereto. Thus, the cathode electrode 250 may be deposited in the separation space between the partition wall 230 and the bank 220 in a process of depositing the cathode electrode 250.

[0077] Although not shown, an encapsulation layer may be further formed on the cathode electrode 250, and may prevent penetration of water. The encapsulation layer may use various materials known to those skilled in the art. Also,

although not shown, a color filter may be further formed for each pixel and on the cathode electrode 250. For example, white light may be emitted from the organic emission layer 240.

[0078] The gate insulation layer 120, the interlayer dielectric 140, the signal pad 300, the passivation layer 165, and a first pad electrode 400 may be formed in the pad area PA of the substrate 100. The gate insulation layer 120 may be formed on the substrate 100, and the interlayer dielectric 140 may be formed on the gate insulation layer 120. The gate insulation layer 120 and the interlayer dielectric 140 may extend from the active area AA and may be formed all over the pad area PA.

[0079] The signal pad 300 may be formed on the interlayer dielectric 140. The signal pad 300 may be formed on the same layer as a layer where the source electrode 150 and the drain electrode 160 in the active area AA are disposed.

[0080] The signal pad 300 may include a lower signal pad 301 and an upper signal pad 302. The lower signal pad 301 may be formed between the interlayer dielectric 140 and the upper signal pad 302, and may enhance an adhesive force between the interlayer dielectric 140 and the upper signal pad 302. Also, the lower signal pad 301 may prevent a bottom of the upper signal pad 302 from being corroded. Therefore, an oxidation rate of the lower signal pad 301 may be lower than that of the upper signal pad 302. That is, the lower signal pad 301 may be formed of a material having a stronger corrosion resistance than a material forming the upper signal pad 302. As described above, the lower signal pad 301 may be formed of an alloy (MoTi) of molybdenum (Mo) and titanium (Ti), which may be similar to the above-described material of the lower source electrode 151 or the lower drain electrode 161, but embodiments are not limited thereto.

[0081] The upper signal pad 302 may be formed on a top of the lower signal pad 301. The upper signal pad 302 may be formed of copper (Cu), which is metal having a low resistance, but embodiments are not limited thereto. The upper signal pad 302 may be formed of metal which is relatively lower in resistance than the lower signal pad 301. To lower a total resistance of the signal pad 300, the upper signal pad 302 may be thicker than the lower signal pad 301.

[0082] The upper signal pad 302 may be formed of the same material as that of the upper source electrode 152 and/or the upper drain electrode 162, and may have the same thickness as that of the upper source electrode 152 and/or the upper drain electrode 162. The lower signal pad 301 may be formed of the same material as that of the lower source electrode 151 and/or the lower drain electrode 161, and may have the same thickness as that of the lower source electrode 151 and/or the lower drain electrode 161. For example, the signal pad 300 and the source electrode 150; the signal pad 300 and the drain electrode 160; or the signal pad 300, the source electrode 150, and the drain electrode 160 may be formed simultaneously through the same process.

[0083] The passivation layer 165 may be formed on the signal pad 300. The passivation layer 165 may extend from the active area AA. A sixth contact hole CH6 exposing a portion of the signal pad 300 may be included in the passivation layer 165. The first pad electrode 400 may be formed on the passivation layer 165. The first pad electrode 400 may be connected to the signal pad 300 through the sixth contact hole CH6. The first pad electrode 400 may be exposed to the outside and connected to an external driver.

[0084] The first pad electrode 400 may protect a top of the signal pad 300. The top of the signal pad 300 may be configured by the upper signal pad 302 which is relatively vulnerable to corrosion. Thus, the first pad electrode 400 may be formed to cover the top of the upper signal pad 302 exposed through the sixth contact hole CH6, thereby preventing the upper signal pad 302 from being corroded. As described above, because the first pad electrode 400 may prevent the top of the upper signal pad 302 from being corroded, the signal pad 300 may be formed in the above-described two-layer structure. An oxidation rate of the first pad electrode 400, e.g., an oxidation rate of the first cover pad electrode 403, may be lower than that of the upper signal pad 302. That is, the first pad electrode 400, e.g., the first cover pad electrode 403, may be formed of a material having a stronger corrosion resistance than a material forming the upper signal pad 302. Also, because the first pad electrode 400 may be exposed to the outside, the first cover pad electrode 403 corresponding to an uppermost surface of the first pad electrode 400 may be formed of a material having a strong corrosion resistance.

[0085] The first pad electrode 400 may be formed of the same material as that of the first anode electrode 180 and/or the first auxiliary electrode 190, and may have the same thickness as that of the first anode electrode 180 and/or the first auxiliary electrode 190. In some embodiments, the first pad electrode 400 and the first anode electrode 180 and/or the first auxiliary electrode 190 may be pattern-formed through the same mask process. The first pad electrode 400 may include a first lower pad electrode 401, a first upper pad electrode 402, and a first cover pad electrode 403.

[0086] The first lower pad electrode 401 may be formed to cover a top of the upper signal pad 302 through the sixth contact hole CH6, thereby preventing the upper signal pad 302 from being corroded. To this end, an oxidation rate of the first lower pad electrode 401 may be lower than that of the upper signal pad 302. That is, the first lower pad electrode 401 may be formed of a material having a stronger corrosion resistance than a material forming the upper signal pad 302. As described above, the first lower pad electrode 401 may prevent the top of the upper signal pad 302 from being corroded. Thus, the signal pad 300 may be formed in the above-described two-layer structure. The first lower pad electrode 401 may be formed of an alloy (MoTi) of molybdenum (Mo) and titanium (Ti), which may be similar to the above-described material of the first lower anode electrode 181 and/or the first lower auxiliary electrode 191, but embodiments are not limited thereto. The first lower pad electrode 401 may be formed of the same material as that of the first lower anode electrode 181 and/or the first lower auxiliary electrode 191, and may have the same thickness as that of the first lower anode electrode 181 and/or the first lower auxiliary electrode 191. For example, the first lower pad electrode 401 and the first lower anode electrode 181; the first lower pad electrode 401 and the first lower auxiliary electrode 191; or the first lower pad electrode 401, the first lower anode electrode 181, and the first lower auxiliary electrode 191 may be pattern-formed through the same mask process.

[0087] The first upper pad electrode 402 may be formed between the first lower pad electrode 401 and the first cover pad electrode 403. The first upper pad electrode 402 may be formed of copper (Cu), which is a metal having a low resistance, but embodiments are not limited thereto. The first

upper pad electrode 402 may be formed of a metal that is relatively lower in resistance than the first lower pad electrode 401 and the first cover pad electrode 403. To lower a total resistance of the first pad electrode 400, the first upper pad electrode 402 may be thicker than each of the first lower pad electrode 401 and the first cover pad electrode 403. The first upper pad electrode 402 may be formed of the same material as that of the first upper anode electrode 182 and/or the first upper auxiliary electrode 192 to have the same thickness as that of the first upper anode electrode 182 and/or the first upper auxiliary electrode 192. For example, the first upper pad electrode 402 and the first upper anode electrode 182; the first upper pad electrode 402 and the first upper auxiliary electrode 192; or the first upper pad electrode 402, the first upper anode electrode 182, and the first upper auxiliary electrode 192 may be pattern-formed through the same mask process.

[0088] The first cover pad electrode 403 may be formed on the first upper pad electrode 402. The first cover pad electrode 403 may be formed to cover a top and a side surface of the first upper pad electrode 402, thereby preventing the first upper pad electrode 402 from being corroded. That is, the first cover pad electrode 403 may prevent the first upper pad electrode 402 from being exposed to the outside. An oxidation rate of the first cover pad electrode 403 may be lower than that of the first upper pad electrode 402. That is, the first cover pad electrode 403 may be formed of a material having a stronger corrosion resistance than a material forming the first upper pad electrode 402.

[0089] The first cover pad electrode 403 may cover up to a side surface of the first lower pad electrode 401. An oxidation rate of the first cover pad electrode 403 may be lower than that of the first lower pad electrode 401. That is, the first cover pad electrode 403 may be formed of a material having a stronger corrosion resistance than a material forming the first lower pad electrode 401. The first cover pad electrode 403 may be formed of a transparent conductive material, such as ITO or the like, but embodiments are not limited thereto. The first cover pad electrode 403 may be formed of the same material as that of the first cover anode electrode 183 and/or the first cover auxiliary electrode 193, and may have the same thickness as that of the first cover anode electrode 183 and/or the first cover auxiliary electrode 193. For example, the first cover pad electrode 403 and the first cover anode electrode 183; the first cover pad electrode 403 and the first cover auxiliary electrode 193; or the first cover pad electrode 403, the first cover anode electrode 183, and the first cover auxiliary electrode 193 may be pattern-formed through the same mask process.

[0090] FIG. 3 is a cross-sectional view of an organic light-emitting display apparatus according to an example embodiment of the present disclosure. The organic light-emitting display apparatus of FIG. 3 is the similar to the above-described organic light-emitting display apparatus of FIG. 2, except that structures of a second anode electrode 200 and a second auxiliary electrode 210 are changed and a second pad electrode 500 is further provided. Thus, like reference numerals refer to like elements. Hereinafter, elements different from the above-described elements of FIG. 2 will be described in detail.

[0091] As shown in FIG. 3, according to an embodiment of the present disclosure, the second anode electrode 200 may include a second center anode electrode 202 and a second upper anode electrode 203, and the second lower

anode electrode **201** of the FIG. 2 example may be omitted. Also, the second auxiliary electrode **210** may include a second center auxiliary electrode **212** and a second upper auxiliary electrode **213**, and the second lower auxiliary electrode **211** of the FIG. 2 example may be omitted.

[0092] In such a structure, the second center anode electrode **202** and the second center auxiliary electrode **212** may be formed of a material, such as an alloy (MoTi) of molybdenum (Mo) and titanium (Ti), which are good in reflectivity and are good in corrosion resistance, but embodiments are not limited thereto.

[0093] According to an embodiment of the present disclosure, the second pad electrode **500** may be further formed on the first pad electrode **400**. Because the second pad electrode **500** is further provided, a height of a pad part may increase, and a contact area may increase, whereby the second pad electrode **500** may be more easily connected to an external driver. The second pad electrode **500** may be formed of the same material as that of the second anode electrode **200** and/or the second auxiliary electrode **210** having a two-layer structure, and may have the same thickness as that of the second anode electrode **200** and/or the second auxiliary electrode **210**. For example, the second pad electrode **500** and the second anode electrode **200**; the second pad electrode **500** and the second auxiliary electrode **210**; or the second pad electrode **500**, the second anode electrode **200**, and the second auxiliary electrode **210** may be patterned through the same mask process.

[0094] The second pad electrode **500** may include a second center pad electrode **502** and a second upper pad electrode **503**. The second center pad electrode **502** may be formed of the same material as that of the second center anode electrode **202** and/or the second center auxiliary electrode **212**. The second upper pad electrode **503** may be formed of the same material as that of the second upper anode electrode **203** and/or the second upper auxiliary electrode **213**.

[0095] According to an embodiment, a side surface of the second center pad electrode **502** may be exposed to the outside, but because the second center pad electrode **502** may be formed of a material which has good corrosion resistance, the second center pad electrode **502** may be prevented from being corroded. Also, the second upper pad electrode **503** may be exposed to the outside, but because the second upper pad electrode **503** may be formed of a material which is good in corrosion resistance, the second upper pad electrode **503** may be prevented from being corroded.

[0096] FIGS. 4A to 4K are cross-sectional views illustrating a method of manufacturing an organic light-emitting display apparatus according to an example embodiment of the present disclosure. The FIGS. 4A to 4K examples illustrate a method of manufacturing the above-described organic light-emitting display apparatus of the example of FIG. 2. Thus, like reference numerals refer to like elements, and in a material and a structure of each element, the same or similar descriptions may not be repeated.

[0097] First, as shown in FIG. 4A, an active layer **110**, a gate insulation layer **120**, a gate electrode **130**, an interlayer dielectric **140**, a source electrode **150**, a drain electrode **160**, and a signal pad **300** may be sequentially formed on a substrate **100**.

[0098] The active layer **110** may be formed on the substrate **100**, the gate insulation layer **120** may be formed on the active layer **110**, the gate electrode **130** may be formed

on the gate insulation layer **120**, the interlayer dielectric **140** may be formed on the gate electrode **130**, and a first contact hole CH1 and a second contact hole CH2 may be formed in the gate insulation layer **120** and the interlayer dielectric **140**. Subsequently, the drain electrode **160** (which may be connected to one end region of the active layer **110** through the first contact hole CH1), the source electrode **150** (which may be connected to the other end region of the active layer **110** through the second contact hole CH2), and the signal pad **300** may be formed.

[0099] Here, the active layer **110**, the gate electrode **130**, the source electrode **150**, and the drain electrode **160** may be formed in an active area AA. The gate insulation layer **120** and the interlayer dielectric **140** may be formed to extend from the active area AA to a pad area PA. The signal pad **300** may be formed in the pad area AA. As such, a TFT T may be formed in the active area AA, and the signal pad **300** may be formed in the pad area PA.

[0100] The source electrode **150** may include a lower source electrode **151** and an upper source electrode **152**. The drain electrode **160** may include a lower drain electrode **161** and an upper drain electrode **162**. The signal pad **300** may include a lower signal pad **301** and an upper signal pad **302**. The source electrode **150**, the drain electrode **160**, and the signal pad **300** may be formed simultaneously of the same material by the same patterning process.

[0101] Subsequently, as shown in FIG. 4B, a passivation layer **165** may be formed on the source electrode **150**, the drain electrode **160**, and the signal pad **300**; and a first planarization layer **171** may be formed on the passivation layer **165**. The passivation layer **165** may be formed to extend from the active area AA to the pad area PA, and the first planarization layer **171** may be formed in the active area AA.

[0102] The passivation layer **165** and the first planarization layer **171** may be formed to include a third contact hole CH3 in the active area AA, and the source electrode **150** may be exposed to the outside through the third contact hole CH3. Also, the passivation layer **165** may be formed to include a sixth contact hole CH6 in the pad area PA, and the signal pad **300** may be exposed to the outside through the sixth contact hole CH6.

[0103] According to an embodiment of the present disclosure, the third contact hole CH3 for externally exposing the source electrode **150** and the sixth contact hole CH6 for externally exposing the signal pad **300** may be formed simultaneously. Thus, the third contact hole CH3 and the sixth contact hole CH6 may be formed through one mask process, thereby preventing the number of mask processes from increasing. Because the upper signal pad **302** exposed by the sixth contact hole CH6 may be vulnerable to corrosion, an etchant may not be brought in contact with the upper signal pad **302**. According to an embodiment of the present disclosure, the exposed upper signal pad **302** may be covered by a lower pad electrode **401** in a process of FIG. 4C described below. Thus, the etchant may not be brought in contact with the upper signal pad **302**. For the same reason, the sixth contact hole CH6 and the third contact hole CH3 may be simultaneously formed.

[0104] Subsequently, as shown in FIG. 4C, a first anode electrode **180** and a first auxiliary electrode **190** may be formed to be separated from each other on the first pla-

narization layer 171 in the active area AA. A first pad electrode 400 may be formed on the passivation layer 165 in the pad area PA.

[0105] The first anode electrode 180 may be formed to be connected to the source electrode 150 through the third contact hole CH3. The first pad electrode 400 may be formed to be connected to the signal pad 300 through the sixth contact hole CH6. In some embodiments, the first anode electrode 180 may be formed to be connected to the drain electrode 160 through the third contact hole CH3 that is formed to expose the drain electrode 160.

[0106] The first anode electrode 180 may be configured with a first lower anode electrode 181, a first upper anode electrode 182, and a first cover anode electrode 183. The first auxiliary electrode 190 may be configured with a first lower auxiliary electrode 191, a first upper auxiliary electrode 192, and a first cover auxiliary electrode 193. The first pad electrode 400 may be configured with a first lower pad electrode 401, a first upper pad electrode 402, and a first cover pad electrode 403. The first anode electrode 180, the first auxiliary electrode 190, and the first pad electrode 400 may be simultaneously formed of the same material through the same patterning process.

[0107] Subsequently, as shown in FIG. 4D, a second planarization layer 172 may be formed on a first anode electrode 180 and a first auxiliary electrode 190 in the active area AA. The second planarization layer 173 may be formed to include a fourth contact hole CH4 and a fifth contact hole CH5. The first anode electrode 180 may be exposed to the outside through the fourth contact hole CH4. The first auxiliary electrode 190 may be exposed to the outside through the fifth contact hole CH5.

[0108] Subsequently, as shown in FIG. 4E, the first photoresist pattern 610 may be formed on the first pad electrode 400 in the pad area PA. The first pad electrode 400 may be covered by the first photoresist pattern 610, and thus may not be exposed to the outside. The first photoresist pattern 610 may not be formed in the active area AA.

[0109] Subsequently, as shown in FIG. 4F, an electrode layer for a second anode electrode (labeled as 200 in FIG. 4G) and a second auxiliary electrode (labeled as 210 in FIG. 4G) may be formed in the pad area PA and the active area AA. In more detail, a lower electrode layer 1, an intermediate electrode layer 2, and an upper electrode layer 3 may be sequentially formed on the first photoresist pattern 610 in the pad area PA and the second planarization layer 172 in the active area AA. Also, a second photoresist pattern 620 may be formed on the electrode layer, e.g., the upper electrode layer 3 in the active area AA.

[0110] Subsequently, as shown in FIG. 4G, a second anode electrode 200 and a second auxiliary electrode 210 may be formed by etching the lower electrode layer 1, the intermediate electrode layer 2, and the upper electrode layer 3 with the second photoresist pattern 620 as a mask. That is, the second photoresist pattern 620 may be formed as a pattern corresponding to a pattern of each of the second anode electrode 200 and the second auxiliary electrode 210. Therefore, a portion of the lower electrode layer 1, a portion of the intermediate electrode layer 2, and a portion of the upper electrode layer 3 that are not covered by the second photoresist pattern 620 may be removed by the etching process, and portions covered by the second photoresist pattern 620 may remain, thereby forming the pattern of each of the second anode electrode 200 and the second auxiliary elec-

trode 210. As a result, the second anode electrode 200 and the second auxiliary electrode 210 may be simultaneously formed of the same material through the same patterning process.

[0111] The second anode electrode 200 may include a second lower anode electrode 201, a second center anode electrode 202, and a second upper anode electrode 203. The second auxiliary electrode 210 may include a second lower auxiliary electrode 211, a second center auxiliary electrode 212, and a second upper auxiliary electrode 213.

[0112] When the portion of the lower electrode layer 1, the portion of the intermediate electrode layer 2, and the portion of the upper electrode layer 3 that are not covered by the second photoresist pattern 620 are removed by the etching process, the first pad electrode 400 may not be damaged by an etchant because the first photoresist pattern 610 covers the first pad electrode 400.

[0113] Subsequently, as shown in FIG. 4H, the first photoresist pattern 610 and the second photoresist pattern 620 may be removed by a strip process. Therefore, the pad electrode 400, the first anode electrode 200, and the second auxiliary electrode 210 may be exposed to the outside.

[0114] FIGS. 4E to 4H illustrate to a method of forming the second anode electrode 200 and the second auxiliary electrode 210 without the first pad electrode 400 being damaged. According to an embodiment of the present disclosure, the first photoresist pattern 610 may be formed on the first pad electrode 400 to cover the first pad electrode 400. Thus, the first pad electrode 400 may not be damaged by an etchant in forming the pattern of each of the second anode electrode 200 and the second auxiliary electrode 210. Also, because the first photoresist pattern 610 may be removed simultaneously with the second photoresist pattern 620, a manufacturing process may be simplified.

[0115] Instead of using the first photoresist pattern 610, the second planarization layer 172 may be formed to cover the first pad electrode 400 by extending the second planarization layer 172 to the pad area PA. Then, the second anode electrode 200 and the second auxiliary electrode 210 may be formed, in the above-described process of FIG. 4D. However, in one example, a process of removing a region of the second planarization layer 172 extending to the pad area PA through an oxygen (O₂) ashing process may be further performed after the second anode electrode 200 and the second auxiliary electrode 210 are formed to externally expose the first pad electrode 400. For example, a photoresist pattern may be further formed as a mask for the process of removing the region of the second planarization layer 172 extending to the pad area PA. Moreover, due to the oxygen (O₂) ashing process, the inside of a chamber may be contaminated, and a process time may increase. Therefore, as described above with reference to the examples of FIGS. 4E to 4H, the first photoresist pattern 610 may be used.

[0116] Subsequently, as shown in FIG. 4I, a bank 220 may be formed on both sides of the second anode electrode 200 to expose a top of the second anode electrode 200. Also, the bank 220 may be formed on both sides of the second auxiliary electrode 210 to expose a top of the second auxiliary electrode 210.

[0117] Moreover, a first partition wall 231 and a second partition wall 232 may be sequentially formed on the exposed top of the second auxiliary electrode 210. The first partition wall 231 may be formed of the same material as

that of the bank 220, which may be through the same pattern forming process as that of the bank 220, and may be formed simultaneously with the bank 220. The partition wall 230 may be formed to be separated from the bank 220 by a certain (e.g., predetermined) distance. Thus, a separation space may be provided between the partition wall 230 and the bank 220.

[0118] For a top of the partition wall 230 to act as eaves, a width of a top of the second partition wall 232 may be formed greater than that of a bottom of the second partition wall 232. For example, with respect to a front view of the organic light-emitting display apparatus, the top of the second partition wall 232 may cover the separation space between the partition wall 230 and the bank 220. Thus, in a below-described process of depositing an organic emission layer 240, the organic emission layer 240 may not be deposited in the separation space between the partition wall 230 and the bank 220.

[0119] Subsequently, as shown in FIG. 4J, the organic emission layer 240 may be formed on the second anode electrode 200. The organic emission layer 240 may be formed by a deposition process, such as an evaporation process, which may be excellent in terms of accuracy and straightness of deposition of a deposited material. However, embodiments are not limited thereto. Thus, the organic emission layer 240 may be deposited on top of the bank 220 and the partition wall 230, but the organic emission layer 240 may not be deposited in the separation space between the partition wall 230 and the bank 220. That is, the top of the partition wall 230 may act as the eaves in depositing the organic emission layer 240. Thus, even when the organic emission layer 240 is deposited without a mask pattern that covers the top of the second auxiliary electrode 210, the organic emission layer 240 may not be deposited in the separation space between the partition wall 230 and the bank 220.

[0120] Subsequently, as shown in FIG. 4K, a cathode electrode 250 may be formed on the organic emission layer 240. The cathode electrode 250 may be formed to be connected to the second auxiliary electrode 210 through the separation space between the partition wall 230 and the bank 220. The cathode electrode 250 may be formed by a deposition process, which may not be as accurate or provide as much straightness of deposition of a deposited material. However, embodiments are not limited thereto. Thus, the cathode electrode 250 may be deposited in the separation space between the partition wall 230 and the bank 220 in a process of depositing the cathode electrode 250.

[0121] FIGS. 5A to 5H are cross-sectional views illustrating a method of manufacturing an organic light-emitting display apparatus according to an example embodiment of the present disclosure. FIGS. 5A to 5H illustrate examples of a method of manufacturing the above-described organic light-emitting display apparatus of FIG. 3. Thus, like reference numerals refer to like elements, and in a material and a structure of each element, the same or similar descriptions may not be repeated.

[0122] First, as shown in FIG. 5A, an active layer 110, a gate insulation layer 120, a gate electrode 130, an interlayer dielectric 140, a source electrode 150, a drain electrode 160, and a signal pad 300 may be sequentially formed on a substrate 100. Therefore, a TFT T may be formed in the

active area AA, and the signal pad 300 may be formed in the pad area PA. Such a process is similar to the above-described process of FIG. 4A.

[0123] Subsequently, as shown in FIG. 5B, a passivation layer 165 may be formed on the source electrode 150, the drain electrode 160, and the signal pad 300. A first planarization layer 171 may be formed on the passivation layer 165. The passivation layer 165 and the first planarization layer 171 may be formed to include a third contact hole CH3 in the active area AA. The source electrode 150 may be exposed to the outside through the third contact hole CH3. Also, the passivation layer 165 may be formed to include a sixth contact hole CH6 in the pad area PA, and the signal pad 300 may be exposed to the outside through the sixth contact hole CH6. Such a process is similar to the above-described process of FIG. 4B.

[0124] Subsequently, as shown in FIG. 5C, a first anode electrode 180 and a first auxiliary electrode 190 may be formed on the first planarization layer 171 in the active area AA, and a first pad electrode 400 may be formed on the passivation layer 165 in the pad area PA. The first anode electrode 180 may be formed to be connected to the source electrode 150 through the third contact hole CH3, and the first pad electrode 400 may be formed to be connected to the signal pad 300 through the sixth contact hole CH6. Such a process is similar to the above-described process of FIG. 4C.

[0125] Subsequently, as shown in FIG. 5D, a second planarization layer 172 may be formed on the first anode electrode 180 and the first auxiliary electrode 190 in the active area AA. The second planarization layer 172 may be formed to include a fourth contact hole CH4 and a fifth contact hole CH5, the first anode electrode 180 may be exposed to the outside through the fourth contact hole CH4, and the first auxiliary electrode 190 may be exposed to the outside through the fifth contact hole CH5. Such a process is similar to the above-described process of FIG. 4D.

[0126] Subsequently, as shown in FIG. 5E, a second anode electrode 200 and a second auxiliary electrode 210 may be formed on the second planarization layer 172 in the active area AA, and a second pad electrode 500 may be formed on the first pad electrode 400 in the pad area PA. The second anode electrode 200 may be connected to the first anode electrode 180 through the fourth contact hole CH4, the second auxiliary electrode 210 may be connected to the second anode electrode 190 through the fifth contact hole CH5, and the second pad electrode 500 may be formed directly on a top of the first pad electrode 400.

[0127] The second anode electrode 200 may include a second center anode electrode 202 and a second upper anode electrode 203. The second auxiliary electrode 210 may include a second center auxiliary electrode 212 and a second upper auxiliary electrode 213. The second pad electrode 500 may include a second center pad electrode 502 and a second upper pad electrode 503. The second anode electrode 200, the second auxiliary electrode 210, and the second pad electrode 500 may be simultaneously formed of the same material through the same patterning process. Thus, an additional mask process is not necessary.

[0128] A first cover pad electrode 403 formed on an uppermost surface of the first pad electrode 400 may be formed of the same material (for example, ITO, which has good corrosion resistance) as that of the second upper pad electrode 503 formed on an uppermost surface of the second pad electrode 500. For example, when the second pad

electrode **500** is pattern-formed, it may be desirable to prevent a pattern of the first cover pad electrode **403** from being damaged. As such, the second pad electrode **500** may be formed through a process in which an electrode material for the second center pad electrode **502** and an electrode material for the second upper pad electrode **503** may be sequentially deposited, the second upper pad electrode **503** may be pattern-formed by etching the electrode material for the second center pad electrode **502**, and the second center pad electrode **502** may be subsequently pattern-formed by etching the electrode material for the second upper pad electrode **503**. That is, the first cover pad electrode **403** may be covered by the electrode material for the second center pad electrode **502** when etching the electrode material for the second upper pad electrode **503**. Thus, an etchant for etching the electrode material for the second upper pad electrode **503** may not be brought into contact with the first cover pad electrode **403**, thereby preventing a pattern of the first upper pad electrode **403** from being damaged.

[0129] Subsequently, as shown in FIG. 5F, a bank **220** may be formed on both sides of the second anode electrode **200** to expose a top of the second anode electrode **200**. Also, the bank **220** may be formed on both sides of the second auxiliary electrode **210** to expose a top of the second auxiliary electrode **210**. Also, a first partition wall **231** and a second partition wall **232** may be sequentially formed on the exposed top of the second auxiliary electrode **210**. The partition wall **230** may be formed to be separated from the bank **220** by a certain (e.g., a predetermined) distance. Thus, a separation space may be provided between the partition wall **230** and the bank **220**. Such a process is similar to the above-described process of FIG. 4I.

[0130] Subsequently, as shown in FIG. 5G, an organic emission layer **240** may be formed on the second anode electrode **200**. The organic emission layer **240** may be deposited on top of the bank **220** and the partition wall **230**, but is not deposited in the separation space between the partition wall **230** and the bank **220**. Such a process is similar to the above-described process of FIG. 4J.

[0131] Subsequently, as shown in FIG. 5H, a cathode electrode **250** may be formed on the organic emission layer **240**. The cathode electrode **250** may be formed to be connected to the second auxiliary electrode **210** through the separation space between the partition wall **230** and the bank **220**. Such a process is similar to the above-described process of FIG. 4K.

[0132] According to embodiments of the present disclosure, the first pad electrode may be formed to cover the top of the signal pad, thereby preventing the signal pad from being corroded. Accordingly, the signal pad may be formed in a two-layer structure which may include the lower signal pad and the upper signal pad vulnerable to corrosion. For example, because the first pad electrode and the first auxiliary electrode may be simultaneously formed of the same material, the number of mask processes may not increase. Moreover, according to embodiments of the present disclosure, the contact hole for externally exposing the source electrode and the contact hole for externally exposing the signal pad may be simultaneously formed. Thus, the number of mask processes may not increase.

[0133] Moreover, according to embodiments of the present disclosure, the two auxiliary electrodes (for example, the first and second auxiliary electrodes) may be formed for lowering the resistance of the cathode electrode. Thus, the

desired resistance characteristic of the auxiliary electrode may be more easily adjusted. For example, the first auxiliary electrode connected to the second auxiliary electrode through the contact hole may be further formed under the second auxiliary electrode, and the resistance of the cathode electrode may be effectively lowered even without any reduction in a pixel area.

[0134] It will be apparent to those skilled in the art that various modifications and variations can be made in the present disclosure without departing from the spirit or scope of the invention. Thus, it is intended that embodiments of the present disclosure cover the modifications and variations of this invention provided they come within the scope of the appended claims and their equivalents.

1-16. (canceled)

17. An organic light-emitting display apparatus, comprising:

a substrate comprising an active area and a pad area;
a thin film transistor in the active area of the substrate, the thin film transistor including a source electrode and a drain electrode;

an anode electrode in the active area of the substrate;
an organic emission layer on the anode electrode; and
a cathode electrode on the organic emission layer;
wherein the anode electrode includes a first anode electrode connected with the source electrode,

wherein the first anode electrode comprises:

a first lower anode electrode;

a first upper anode electrode; and

a first cover anode electrode,

wherein the first cover anode electrode covers a top and a side surface of the first upper anode electrode, and
wherein the first cover anode electrode covers up to a side surface of the first lower anode electrode.

18. The organic light-emitting display apparatus of claim 17, wherein:

an oxidation rate of the first cover anode electrode is lower than oxidation rate of the first upper anode electrode; and

an oxidation rate of the first cover anode electrode is lower than oxidation rate of the first lower anode electrode.

19. The organic light-emitting display apparatus of claim 17, wherein the anode electrode further includes a second anode electrode connected to the first anode electrode through a contact hole.

20. The organic light-emitting display apparatus of claim 19, further comprising:

an auxiliary electrode in the active area of the substrate and directly connected to the cathode electrode,

wherein the auxiliary electrode comprises:

a first auxiliary electrode; and

a second auxiliary electrode connected to the first auxiliary electrode through a contact hole.

21. The organic light-emitting display apparatus of claim 20, wherein a width of the first auxiliary electrode is greater than a width of the first anode electrode.

22. The organic light-emitting display apparatus of claim 20, wherein the first auxiliary electrode and the first anode electrode are on a same layer.

23. The organic light-emitting display apparatus of claim 20, wherein the first auxiliary electrode comprises:

a first lower auxiliary electrode;

a first upper auxiliary electrode; and

- a first cover auxiliary electrode
 wherein the first lower auxiliary electrode comprises a same material as the first lower anode electrode,
 wherein the first upper auxiliary electrode comprises a same material as the first upper anode electrode, and
 wherein the first cover auxiliary electrode includes a same material as the first cover anode electrode.
- 24.** The organic light-emitting display apparatus of claim **23**, wherein:
 the first cover auxiliary electrode covers a top and a side surface of the first upper auxiliary electrode; and
 the first cover auxiliary electrode covers up to a side surface of the first lower auxiliary electrode.
- 25.** The organic light-emitting display apparatus of claim **23**, wherein:
 an oxidation rate of the first cover auxiliary electrode is lower than oxidation rate of the first upper auxiliary electrode; and
 an oxidation rate of the first cover auxiliary electrode is lower than oxidation rate of the first lower auxiliary electrode.
- 26.** The organic light-emitting display apparatus of claim **20**, further comprising:
 a signal pad in the pad area of the substrate; and
 a first pad electrode connected to the signal pad,
 wherein the first pad electrode covers a top of the signal pad.
- 27.** The organic light-emitting display apparatus of claim **26**, wherein:
 the signal pad comprises:
 a lower signal pad; and
 an upper signal pad; and
 an oxidation rate of the lower signal pad is lower than oxidation rate of the upper signal pad.
- 28.** The organic light-emitting display apparatus of claim **26**, wherein the first pad electrode comprises:
 a first lower pad electrode;
 a first upper pad electrode; and
 a first cover pad electrode,
 wherein the first lower pad electrode includes a same material as the first lower anode electrode,
 wherein the first upper pad electrode includes a same material as the first upper anode electrode; and
- wherein the first cover pad electrode includes a same material as the first cover anode electrode.
- 29.** The organic light-emitting display apparatus of claim **28**, wherein:
 the first lower pad electrode includes the same material as the first lower auxiliary electrode;
 the first upper pad electrode includes the same material as the first upper auxiliary electrode; and
 the first cover pad electrode includes the same material as the first cover auxiliary electrode.
- 30.** The organic light-emitting display apparatus of claim **28**, wherein:
 the first cover pad electrode covers a top and a side surface of the first upper pad electrode; and
 the first cover pad electrode covers up to a side surface of the first lower pad electrode.
- 31.** The organic light-emitting display apparatus of claim **28**, wherein:
 an oxidation rate of the first cover pad electrode is lower than oxidation rate of the first upper pad electrode; and
 an oxidation rate of the first cover pad electrode is lower than oxidation rate of the first lower pad electrode.
- 32.** The organic light-emitting display apparatus of claim **20**, wherein the first auxiliary electrode overlaps the second anode electrode.
- 33.** The organic light-emitting display apparatus of claim **26**, further comprising a second pad electrode on the first pad electrode.
- 34.** The organic light-emitting display apparatus of claim **33**, wherein the second pad electrode comprises a same material as the second auxiliary electrode.
- 35.** The organic light-emitting display apparatus of claim **27**, wherein a resistance of the upper signal pad is lower than a resistance of the lower signal pad.
- 36.** The organic light-emitting display apparatus of claim **20**, further comprising:
 a bank on both sides of the second auxiliary electrode; and
 a partition wall on the second auxiliary electrode, the partition wall being separated from the bank,
 wherein the cathode electrode is connected to the second auxiliary electrode through a separation space between the bank and the partition wall.

* * * * *

专利名称(译)	有机发光显示装置及其制造方法		
公开(公告)号	US20180166657A1	公开(公告)日	2018-06-14
申请号	US15/889659	申请日	2018-02-06
[标]申请(专利权)人(译)	乐金显示有限公司		
申请(专利权)人(译)	LG DISPLAY CO. , LTD.		
当前申请(专利权)人(译)	LG DISPLAY CO. , LTD.		
[标]发明人	KIM SEJUNE LEE JOONSUK LEE SOJUNG JANG JIN HEE IM JONGHYEOK LEE JAESUNG		
发明人	KIM, SEJUNE LEE, JOONSUK LEE, SOJUNG JANG, JIN-HEE IM, JONGHYEOK LEE, JAESUNG		
IPC分类号	H01L51/56 H01L51/00 H01L27/32 H01L51/52 H01L27/12		
CPC分类号	H01L51/0023 H01L27/3262 H01L27/3276 H01L27/326 H01L27/3248 H01L51/5228 H01L51/5212 H01L27/1248 H01L27/3258 H01L27/3246 H01L2227/323 H01L51/56 H01L51/5237 H01L51/5203 H01L27/124 H01L51/5221		
优先权	1020150075397 2015-05-28 KR		
其他公开文献	US10276838		
外部链接	Espacenet USPTO		

摘要(译)

提供一种有机发光显示装置及其制造方法。一种有机发光显示装置，包括：包括有源区和焊盘区的基板，有源区中的阳极，阳极上的有机发光层，有机发光层上的阴极，连接的辅助电极阴极电极，焊盘区域中的信号焊盘，以及连接到信号焊盘的第一焊盘电极，第一焊盘电极覆盖信号焊盘的顶部，第一焊盘电极配置为防止信号焊盘的顶部由于被腐蚀，其中辅助电极包括通过接触孔连接到第一辅助电极的第一辅助电极和第二辅助电极，并且其中第一焊盘电极包括与第一辅助电极相同的材料。

